

Active FAK 607 XS

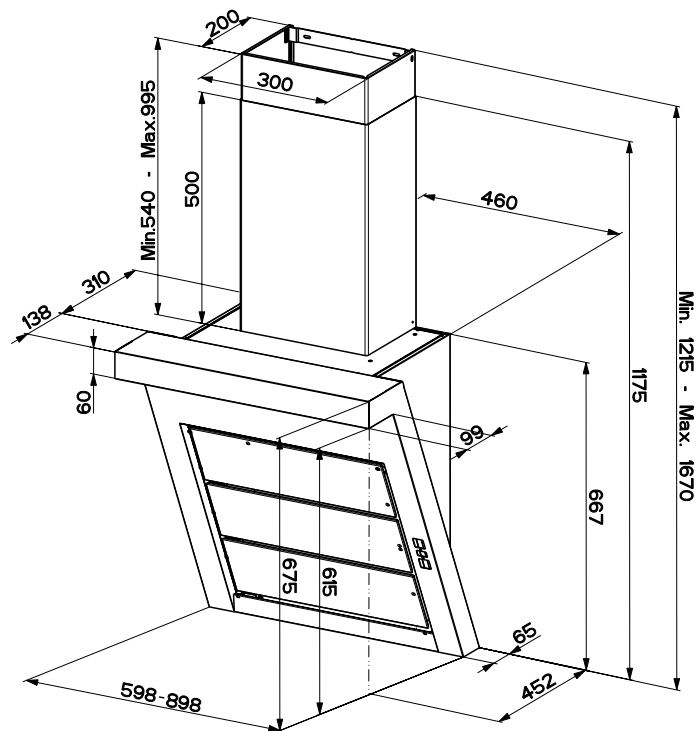

Speed	Flow Rate IEC 61591 [M ³ /H] 1 2	Pressure Maximum [Pa]	Power Input [W]	Sound Power IEC 60704-2-13 [dB(A)]
I	270/260	290	75	45
II	360/340	360	155	51
III	570/510	450	215	60
IV	730/660	480	300	65
Int	820/720	500	340	67

1 (200 m³/h, 5 Pa) Resistance curve according to IEC 61591
 2 (200 m³/h, 15 Pa) Resistance curve according to IEC 61591

Model	FAK 607 XS
Hood type	Wall
Width	60cm
Control type	Electronic
Finish	Stainless Steel
Extraction speed setting	4 + int.
Automatic cut-off timer	■
Continuous 24 hour ventilation	■
Digital Display	■
Filtering function	■
Motor	Energy
Filter type	A
Perimetric extraction	■
Easy fit	
Remote control	Optional
Filter saturation indicator	■
Illumination	Halogen 2 x 20W
Comfort light	■
Grease filter	Aluminium cassette
Outlet tube diameter	150mm (120mm adaptor supplied)