

Chef FCH 906-P XS

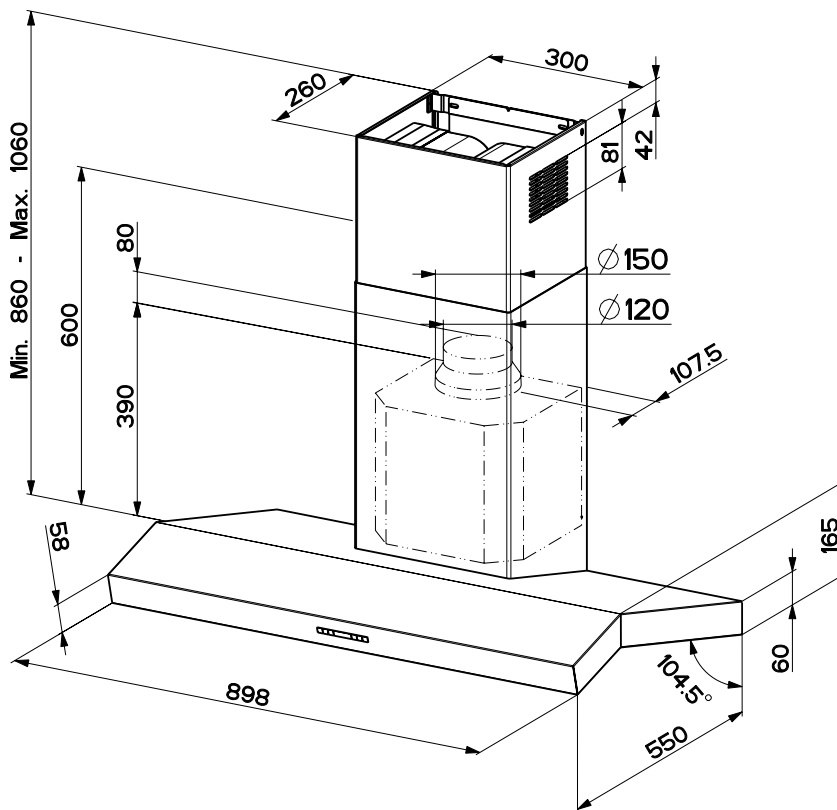

Speed	Flow Rate IEC 61591 [M ³ /H]		Pressure Maximum [Pa]	Power Input [W]	Sound Power IEC 60704-2-13 [dB(A)]
	1	2			
I	270/260		360	135	47
II	430/410		450	170	54
III	570/520		480	215	61
Int	660/600		500	250	65

1 (200 m³/h, 5 Pa) Resistance curve according to IEC 61591
 2 (200 m³/h, 15 Pa) Resistance curve according to IEC 61591

Model	FCH 906-P XS
Hood type	Wall
Width	90cm
Control type	Electronic
Finish	Stainless Steel
Extraction speed setting	3 + int.
Automatic cut-off timer	■
Continuous 24 hour ventilation	
Digital Display	■
Filtering function	■
Motor	ENERGY
Filter type	B
Perimetric extraction	■
Easy fit	■
Remote control	
Filter saturation indicator	
Illumination	Halogen 2 x 20W
Comfort light	
Grease filter	Aluminium cassette
Outlet tube diameter	150mm (120mm adaptor supplied)