

# Luminaire FGL 9016 XS

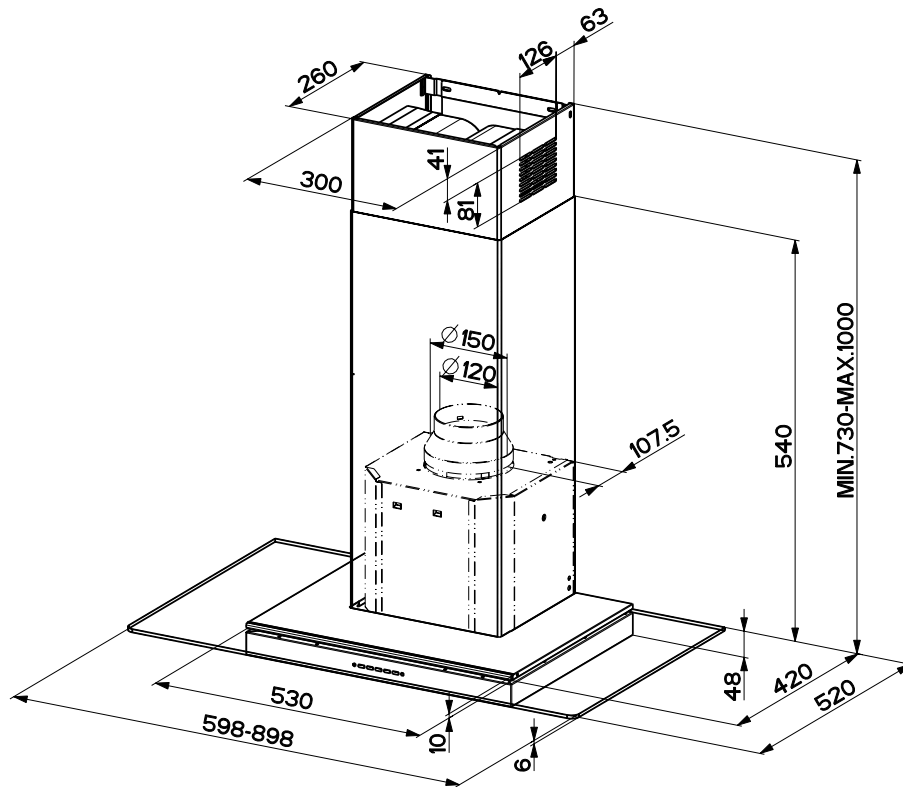

Speed	Flow Rate IEC 61591 [M <sup>3</sup> /H] 1   2	Pressure Maximum [Pa]	Power Input [W]	Sound Power IEC 60704-2-13 [dB(A)]
I	260/250	140	90	51
II	330/310	200	115	55
III	470/430	260	145	63
Int	600/520	280	190	67

1 (200 m<sup>3</sup>/h, 5 Pa) Resistance curve according to IEC 61591

2 (200 m<sup>3</sup>/h, 15 Pa) Resistance curve according to IEC 61591

Model	FGL 9016 XS
Hood type	Wall
Width	90cm
Control type	Electronic
Finish	Stainless Steel
Extraction speed setting	3 + Intensive
Automatic cut-off timer	■
Continuous 24 hour ventilation	
Digital Display	■
Filtering function	■
Motor	HIP
Filter type	B
Perimetric extraction	
Easy fit	■
Remote control	
Filter saturation indicator	
Illumination	Halogen 2 x 20W
Comfort light	
Grease filter	Stainless Steel
Outlet tube diameter	150mm (120mm adaptor supplied)