

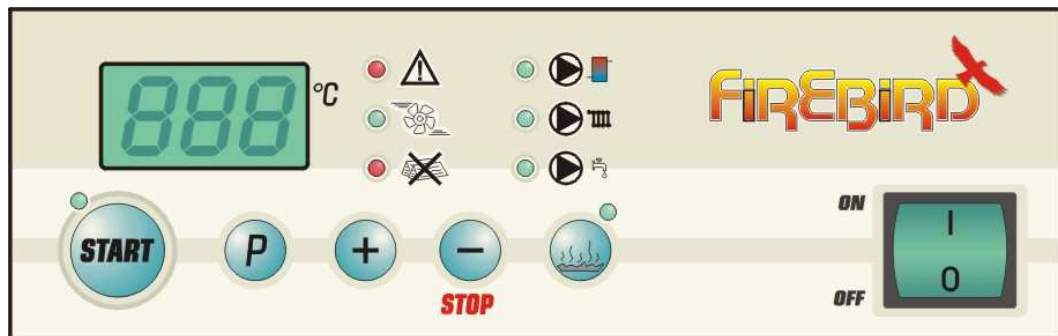

## TECHNICAL MANUAL

### DIGITAL BOILER REGULATION

*Bio-Tec*



## **MENU**

1. INTRODUCTION.....	3
2. FRONT COVER OF THE DIGITAL REGULATOR.....	3
3. CONNECTION TO THE ELECTRICAL POWER NET.....	6
4. FUNCTIONING OF THE REGULATOR.....	7
5. SENSOR RESISTANCE LISTS.....	10

## 1. INTRODUCTION

The electronic regulator of the **Bio-Tec** pyrolysis burning system boiler has steering/protecting function. It steers the fan, pump of the boiler (accumulation), heating pump towards the room thermostat (included into a basic delivery) or the contact thermostat, as well as the sanitary water pump in a parallel mode or with the sanitary water priority.

Depending on the need, the regulator can function in following modes:

### MEASURING MODE

1. display of the measured value
2. display of the measured parameter number

### SETUP MODE

1. display of the parameter value
2. display of the setup parameter number

### FUNCTIONING MODES

1. Back to the preset parameter mode
2. Test regulator exit mode
3. Firing mode (fan start-up)
4. Regulation mode, functioning of the boiler (warming up and fuel consumption control with boiler deactivation)
5. Boiler deactivation mode (fan deactivated by means of the “ - / STOP “ button)

## 2. FRONT COVER OF THE DIGITAL REGULATOR

The front cover of the digital regulator is displayed on the figure 1.

Elements positioned on the front cover have following functions (according to the number):

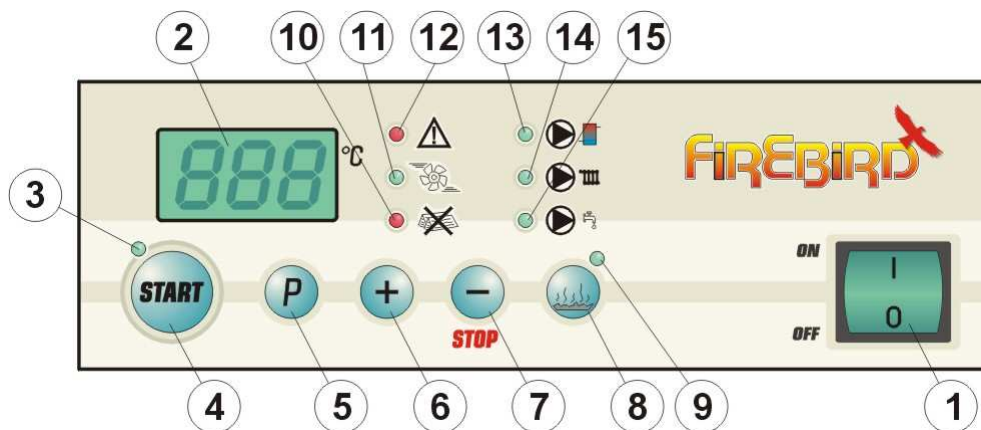

Figure 1. Front cover of the digital regulator

1. Electric power switch for electric power supply of the regulator. It does not switch off supply cables for the steering relays of the regulator. It can be switched on by pushing the button “1”. If the boiler is connected to the electric power net, after the activating of the button the signal light turns on and the LED display 2 shows the boiler temperature. By pushing the button “0” the electric power supply of the regulator shall be interrupted and the signal light of the electric power supply turns off.
2. The LED display shows the measured temperatures, their ordinal number, number or the value of the parameter as well as the signal referred to the mode of the regulator's functioning (“FS” – turn back to the preset parameters or “SE” – testing of regulator's exit). All temperatures shall be displayed in the range from 0°C up to the maximal measured value. The temperatures under 0°C

should be displayed with "LLL" symbol, while the interruption or the short circuit of the sensor shall be displayed with "---" symbol. All temperatures shall be displayed with resolution of 1°C, while the flue exhaust gases temperature shall be displayed with a resolution of 5°C.

3. Indication (LED diode) "START" shows the regulator functioning mode. When it does not show the light, the regulator is switched off. If fluttering, the regulator is in firing mode. Constant light means constant functioning of the boiler.
4. "START" button
  - if the boiler is switched off, by the first pushing the button, the firing mode is activated. LED diode (3) flutters.
  - if the boiler is in firing process, by pushing the "START" button the regulation and fuel consumption control is activated.
  - if the boiler is switched on (i.e. if it is functioning), the button "START" does not react.
5. "P" button
  - by pushing the button "P", if the regulator is not in the SETUP or EXIT TEST mode, the ordinal number of the measurement shall be displayed. This number can be changed by pushing "+" or "-" together with the button "P" (6 or 7). If we stop pushing the button "P", the regulator shall turn to show the measured values.
  - by pushing the button "P" during the SETUP parameters, the regulator shows the ordinal number of the parameters. This number can be changed by pushing "+" or "-" (6 or 7). If we stop pushing the button "P" the regulator turns to show the value of the chosen parameter.
  - by pushing the button "P" together with the button "GLOW" (8) for 3 seconds, the regulator enters into the mode SETUP parameters. The same procedure is valid for exit the mode SETUP parameters. The setup mode is shown by fluttering of the LED display light no. 10 and 12.
  - by pushing the button «P» for 6 seconds during the connection of the regulator to the electric power supply (switch 1), until the signal "FS" appears, the regulator sets all values to the preset parameters.
  -
6. "+" button
  - by pushing the button "+" together with the button "P" during the SETUP, the ordinal number of the parameter is increasing.
  - by pushing the button "+" during the SETUP, the value of the chosen parameter is increasing.
  - by pushing the button "+" together with the button "P" during the MEASUREMENT, the ordinal number of the measurement is increasing.
  -
7. "STOP / -" button
  - if the regulator is in MEASURING mode and if the button "P" (5) has not been pushed, by pushing the button "STOP / -" for 3 seconds the regulator stops the procedure of regulation, i.e. switches off the boiler.
  - by pushing the button "STOP / -" together with the button "P" during the SETUP the ordinal number of the parameter is decreasing.
  - by pushing only the button "STOP / -" during the SETUP, the value of the parameter is decreasing.
  - by pushing the button "STOP / -" together with the button "P" during the MEASUREMENT, the ordinal number of parameter is decreasing.
  -
8. "GLOW" button
  - by pushing the "GLOW" button, the function of burning by keeping the glow switches on/off interchangeably.
  - by pushing the "GLOW" button together with the button "P" (5) during 3 seconds, the regulator turns to the mode SETUP parameter. The same procedure for exiting the mode SETUP parameters. This mode is displayed by fluttering of the LED display no. 10 and 12.
  - by pushing the button "GLOW" for 6 seconds together with the activating of the regulator for supply (1), until the signal "SP" appears, the regulator shall enter into the service mode, in which all relay exits of the regulators can be checked. The pump P1 shall initially be activated and by every further pushing the button "GLOW" the next relay exit shall be activated. After activating the last exit (fan) the pump P1 shall newly be started and the procedure can be repeated.

9. Indication (LED diode) "GLOW" – indicates that the burning by keeping the glow is activated. This burning mode can be activated / deactivated by pushing the button (8).
10. Indication (LED diode) "FUEL" - indicates that after the heating up the boiler the flue gases temperature is still below the setup limit for the burning by keeping/or without the keeping glow. This can mean the absolute fuel consumption, unsuccessful firing or extinction of the boiler after the fan has been deactivated because of security reasons (i.e. one of maximum temperatures inside the systems has been reached).
11. Indication (LED diode) "FAN" shows the activity of the fan.
12. Indication (LED diode) "ERROR" shows that during the fan activity the error appeared (indication starts to appear with an delay of 2,5 seconds after the error actually has appeared). In the same time the LED display flutters every 3 seconds the number of the error together with the symbol "E" (error) each time for 1 second.  
Numbers of errors are following:
  - 1- boiler sensor error
  - 2- flue gases sensor error
  - 3- error on the upper sensor of the first accumulator (if the upper one is not connected, and there is the lower one of the last accumulator)
  - 4- error on the lower sensor of the last accumulator (if the lower one is not connected, and there is an upper sensor of the first accumulator)
  - 5- error on the sensor of sanitary water accumulator (if the parameter which determines the sanitary water accumulator presence is activated)
  - 6- error of the room corrector (thermostat)
  - 7- stand by
  - 8- stand by
13. Indication (LED diode) "Pump P1" - shows the activation of the relay for boiler pump P1 supply.
14. Indication (LED diode) "Pump P2" - shows the activation of the relay for heating pump P2 supply.
15. Indication (LED diode) "Pump P3" - shows the activation of the sanitary water pump P3.

Following lists show measurements and parameters according to the ordinal numbers as per display.

## MEASUREMENTS

Measuring No.	Identification code in manual	Description
1	Tkot	Measured boiler temperature
2	Tsv	Measured sanitary water temperature
3	Tsob	Measured room temperature
4	Ts-namj	Setup room temp. (reading from the room thermostat)
5	Tspr1g	Measured upper temp in the first accumulator (outlet)
6	Tsprzd	Measured lower temp. in the last or first accumulator
7	Tdim	Measured flue gases temp. display scale 5°C

List 1. Measuring numbers

## PARAMETERS

Paramet. No.	Identification code in manual	Factory setup	Description
1	Tsv-namj	50	Setup temperature sanitary water. Adjusting range 20-70°C
2	SV-nacin	0	Sanitary water pump steering mode. 0=parallel functioning, 1=priority sanitary water
3	SPR_SV	0	Parameter which determines if hot water accumulator and sensor are inside the configuration. 0=no accumulator, 1= accumulator connected
4	Tk-max	90	Maximum boiler temperature
5	Tk-hlad	92	Temperature level at which the boiler cooling shall absolutely be activated
6	Tk-P1	65	Boiler temperature level at which the pump (P1) shall absolutely be activated
7	Tdim_max	250	Maximum flue gases temperature. Setup scale 5°C
8	Tdim-izg	85	Flue gases temperature level at which the burning process stops without the glow keeping. Setup scale 5°C
9	Tdim-zar	115	Flue gases temperature level at which the burning process stops with the glow keeping. Setup scale 5°C
10	Vr-ugrij	120	Boiler warming up period (minutes). Measuring starts with each fan activating. After expiry, if the Tk is not over Tdim-izg or Tdim-zar, the signal "FUEL" appears and the boiler shall be deactivated
11	Tspr-max	95	Maximal lower accumulator temperature
12	Td-sob/spr	5	Minimal upper temperature difference between the first accumulator and the room temperature in order to enable the heating pump (Pgrij)

Figure 2. Parameter numbers

### 3. CONNECTION TO THE ELECTRICAL POWER NET

The figure 2 displays the connection.

The pumps, fan and flaps are to be fixed to the ordinal terminal J5. Temperature sensors, room sensor or thermostat are to be fixed to the ordinal terminal J1. All connections are carried out in non coated cables. If only one accumulator is connected, the sensor (O5) has to be fixed as the lower sensor of the single accumulator. Sanitary water sensor (O4) is to be connected only if inside the configuration the parameter «Sv-nacin» (parameter 3) is set on value 1. (functioning with the sanitary water accumulator).

The sensor types are following:

- O1, O3, O4, O5      - NTC 5k
- O2                      - Pt1000
- Correcting room sensor with the room temperature measuring and setting elements. If the contact thermostat is used (contact shall be closed if the temperature is too low), it has to be connected to the ordinal terminal 11 and 12.

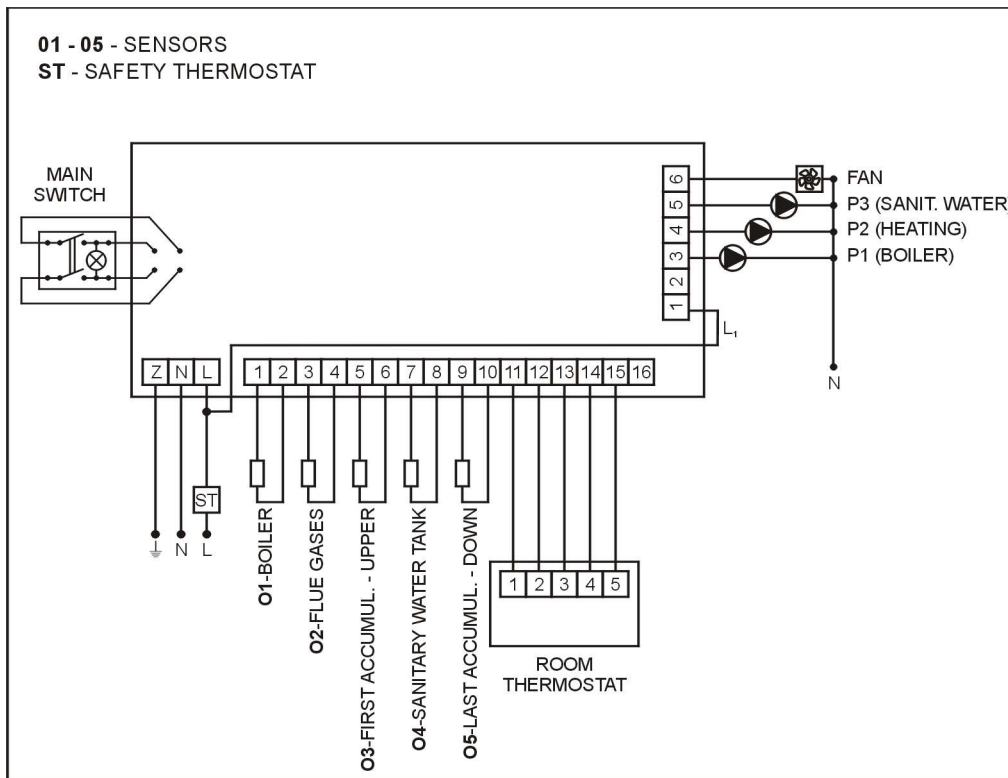

Figure 2. Electrical scheme for the regulator connection

#### 4. FUNCTIONING OF THE DIGITAL REGULATOR

The regulation mode depends on the system configuration. The boiler is functioning so that the fuel is always burning in the optimal regime, i.e. so that the boiler is always functioning with maximum power. This enables its best efficiency, the lowest possible pollution gases radiation, while the damaging of the boiler is minimized. The control of maximum temperatures of all system elements is constantly activated.

To the boiler configuration which assumes the connection of accumulators (displayed by the figure 3), one or more sanitary water accumulators can be integrated. The first accumulator (fixed at the inlet entrance) has an outlet water temperature sensor connected on its upper part (O3). The last accumulator in the chain (i.e. the one which lower connection point is fixed to the boiler outlet) has to have an (O5) sensor on its lower part. If there is only one accumulator inside the configuration, the sensors (O3) and (O5) are connected on both parts – lower and upper – of this single accumulator.

In such configuration there are maximum 3 pumps connected: Pump P1 only for accumulation of boiler energy. Pump 2 is aimed for heating, i.e. for water circulation through radiators. Pump 3 is sanitary water pump.

When the boiler is turned off (LED indication 3 turned off), the fan shall be activated by pushing the button “START” and the boiler shall enter into the firing mode (LED indication flutters). By repeated pushing the button “START” after the firing, the process of warming up and burning of the boiler shall be started (LED indication 3 is constantly burning). In this functioning mode, the flue exhaust gases temperature which is constantly controlled, after the warming up period Vr-ugrij – parameter (10), has to be higher then the setup combustion temperature (Tdim-izg – parameter (8) or Tdim-zar – parameter (9), depending of the fact which type of combustion has been chosen – with the glow keeping or without the glow keeping. The warm up period starts from 0 with each fan activating (the fan deactivating occurs each time because of protecting reasons, i.e. because one of system elements has reached its maximal temperature.

As the boiler and flue gases temperature is increasing, once reached the boiler temperature Tk-P1 – parameter (6), the pump P1 shall be activated. The fan keeps to be activated until one of the limiting conditions has been reached. It restarts the functioning when the conditions are newly fulfilled.

When the flue gases and the boiler temperature start to decrease, because of the lack of fuel and despite the functioning of the fan, the temperature falls until Tdim-izg – parameter (8), in burning-without-glow-keeping mode, or in burning-with-glow-keeping mode, the combustion process shall be terminated.

The fan stops and the pump P1 keeps working for next 5 minutes. The combustion process shall also be terminated if any there is any kind of error present for longer then 5 seconds.

The room temperature starts to steer the pump P2, when the minimum temperature difference in the first accumulator is for Td-sob/spr – parameter (4) higher then the current room temperature. The steering of the pump P2 is independent of the boiler's functioning mode (firing or stand-by mode)

During its functioning the fan shall be automatically **activated** if following conditions are fulfilled:

- boiler temperature Tkot (MJER1) is at least 5°C lower then the maximal boiler temperature Tk-max - parameter (4)
- flue gases temperature Tdim (MJER7) is equal or lower then the maximal flue gases temperature Tdim-max – parameter (7) decreased for 20°C.
- lower temperature of the last connected water accumulator Tsprzd (MJER6) is for at least 5°C lower then the maximal boiler temperature Tspr-max – parameter (11), besides the normal operating temperature of the boiler.

During its functioning the fan shall be automatically **deactivated** if one of following conditions are fulfilled:

- boiler temperature Tkot (MJER1) is equal or higher then the maximal boiler temperature Tk-max - parameter (4).
- flue gases temperature Tdim (MJER7) is equal or higher then the maximal flue temperature Tdim-max – parameter (7).
- lower temperature of the last connected water accumulator Tsprzd (MJER6) is equal or higher then the maximal temperature of the accumulator Tspr-max – parameter (11)

The pump P1 shall be automatically **activated** when:

- the boiler temperature Tk-P1 – parameter (6) exceeds for at least 2°C. This is the basic condition for activating the pump P1.
- the boiler temperature has reached the point of cooling Tk-hlad – parameter (5) even if the lower temperature of the accumulator (MJER6) is at least 2°C lower then the maximal temperature of the accumulator – parameter (11).
- when the boiler is deactivated, follows an additional functioning period of the pump for next 5 minutes.

The Pump P1 is automatically **deactivated** when:

- the boiler temperature falls to the minimal boiler temperature Tk-max – parameter (4), even if the boiler has been in cooling mode Tk-hlad – parameter (5).
- lower temperature of the water accumulator has reached the maximal temperature Tspr-max of the accumulator parameter (11).
- the temperature of the boiler falls to the minimum boiler temperature Tk-P1 - parameter (6).
- after the additional period of pump functioning (5 minutes) the boiler deactivating has been completed.

The pump P2 (heating) shall automatically be **activated** when:

- the room temperature falls for 1°C under the setup room temperature (for room temperature corrector).
- the difference between room temperature and the upper accumulator temperature Tspr1g (MJER5) has reached minimum of Td-sob/spr - parameter (12).
- the contact of the room thermostat has been closed (for room thermostat).
- the boiler temperature has reached the boiler cooling mode temperature Tk-hlad – parameter (5) and the lower temperature of the accumulator Tsprzd (MJER 6) has reached the temperature which is for 10°C lower then the maximal temperature Tspr-max – parameter (11).
- when the sanitary water pump is deactivated and the priority for sanitary water heating has been chosen.

The pump P2 (heating) shall automatically be **deactivated** when

- the room temperature reaches 1°C over the setup temperature level (for room corrector).
- the thermostat contact has been opened (for the room thermostat).
- the boiler temperature level falls until the maximal boiler temperature Tk-max – parameter (4) if the boiler has been in cooling mode Tk-hlad – parameter (5).

- when in the boiler cooling mode the accumulator temperature  $T_{sprzd}$  (MJER 6) falls for  $12^{\circ}\text{C}$  under the maximal accumulator temperature  $T_{spr-max}$  – parameter (11).

Pump P3 (sanitary water) shall automatically be **activated** when the sanitary water sensor (setup by the parameter (3)) and the connected sanitary water sensor O4 is connected and when:

- the upper accumulator temperature  $T_{spr1g}$  (MJER 5) is for  $5^{\circ}\text{C}$  higher then the sanitary water temperature  $T_{sv}$  (MJER 2)
- when the sanitary water temperature is for  $3^{\circ}\text{C}$  lower then the setup temperature  $T_{sv-namj}$  – parameter (1)
- when the boiler is in cooling mode, the lower temperature of the accumulator  $T_{sprzd}$  (MJER 6) has reached the level up to  $10^{\circ}\text{C}$  under the maximal temperature of the accumulator  $T_{spr-max}$  – parameter (11) and the sanitary water is not heated up for more then  $8^{\circ}\text{C}$  over the setup temperature for sanitary water  $T_{sv-namj}$  – parameter (1).

The pump P3 (sanitary water) shall automatically be **deactivated** when the sanitary water accumulator (setup by the parameter (3) , is connected to the system and the sanitary water sensor O4 is not connected or when the sanitary water accumulator is disconnected from the configuration (i.e. the parameter (3) is set on 0) and when:

- the temperature of the accumulator  $T_{spr1g}$  (MJER 5) reaches the level up to  $3^{\circ}\text{C}$  under the temperature of the sanitary water  $T_{sv}$  (MJER 2).
- if the boiler is not in the cooling mode and the temperature of the sanitary water  $T_{sv}$  (MJER 2) has reached the setup temperature of the sanitary water  $T_{sv-namj}$  – parameter (1)
- if the boiler is in the cooling mode and the lower temperature of the accumulator  $T_{sprzd}$  (MJER 6) felt down to  $12^{\circ}\text{C}$  under the maximal boiler temperature  $T_{spr-max}$  – parameter (11)
- if the boiler is in the cooling mode and sanitary water is heated up for  $10^{\circ}\text{C}$  over the setup value  $T_{sv-namj}$  – parameter (1)

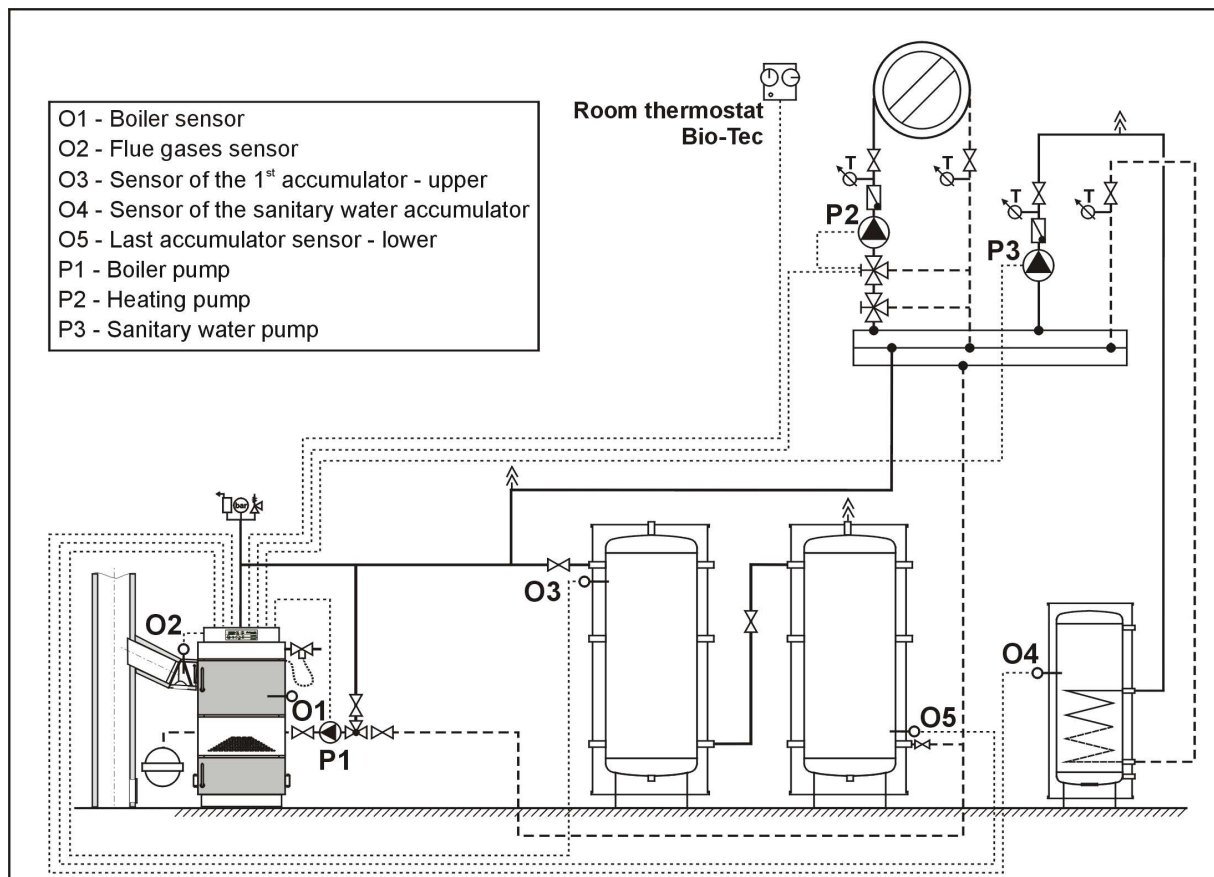

Figure 3. Scheme of the system – connecting points for sensor and pumps

## 5. SENSOR RESISTANCE LISTS

Resistance list NTC 5k/25°C sensor  
(measuring field from -20 to +130°C)

Temperature (°C)	Resistance (Ω)
-20	48.535
-15	36.465
-10	27.665
-5	21.158
0	16.325
5	12.694
10	9.950
15	7.854
20	6.245
25	5.000
30	4.028
35	3.266
40	2.663
45	2.184
50	1.801
55	1.493
60	1.244
65	1.041
70	876
75	740,7
80	629,0
85	536,2
90	458,8
95	394,3
100	340,0
105	294,3
110	255,6
115	222,7
120	190,7
125	170,8
130	150,5

Resistance list **Pt1000** sensor  
(measuring field from – 30 to + 400°C)

Temperature (°C)	Resistance ( Ω )
-30	885
-25	904
-20	923
-15	942
-10	962
-5	981
0	1.000
5	1.019
10	1.039
15	1.058
20	1.077
25	1.096
30	1.116
35	1.135
40	1.154
45	1.173
50	1.193
55	1.212
60	1.231
65	1.250
70	1.270
75	1.289
80	1.308
85	1.327
90	1.347
95	1.366
100	1.385
105	1.404
110	1.424
115	1.443
120	1.462
125	1.481
130	1.501
135	1.520
140	1.539
145	1.558
150	1.578
155	1.597
160	1.616
165	1.635
170	1.655
175	1.674
180	1.693
185	1.712
190	1.732
195	1.751
200	1.770
205	1.789
210	1.809
215	1.828
220	1.847

Temperature (°C)	Resistance ( Ω )
225	1.866
230	1.886
235	1.905
240	1.924
245	1.943
250	1.963
255	1.982
260	2.001
265	2.020
270	2.040
275	2.059
280	2.078
285	2.097
290	2.117
295	2.136
300	2.155
305	2.174
310	2.194
315	2.213
320	2.232
325	2.251
330	2.271
335	2.290
340	2.309
345	2.328
350	2.348
355	2.367
360	2.386
365	2.405
370	2.425
375	2.444
380	2.463
385	2.482
390	2.502
395	2.521
400	2.540

Centrometal d.o.o. company does not take over the responsibility for errors in this manual, which might occur during the printing procedure. In any case the company Centrometal d.o.o. reserves the right to perform changes in its products' manuals if considered as necessary.

v.0.1-1-eng

Macinec, December 2007.