



CLAS HE

WALL-HUNG HIGH EFFICIENCY
GAS BOILERS



Elegant, efficient
and intelligent



The high efficiency boiler that saves on energy and costs



With specified intelligence,
CLAS HE adapts to the
householder's requirements

The CLAS HE range of boilers incorporate Ariston's innovative AUTO function, which enables the boiler to operate more efficiently by intelligently choosing the correct temperature for the central heating circuit.

CLAS HE also features an LCD display which, as well as displaying information on the boiler's operation, will also display an error code in the event of a shut-down to help easily determine the cause.

Home comfort with CLAS HE

- SEDBUK Band A
- NOx Class 5
- High combi DHW flow rates
15.6 l/min $\Delta T = 35^{\circ}\text{C}$ (38kW model)
- Compact dimensions
- 2 year guarantee
- Self diagnostic display
- Multiple flue options
- Extensive range of controls and accessories available
- Stainless steel heat exchanger

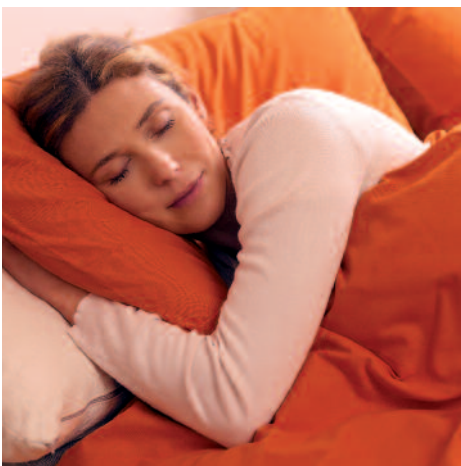

Easy to
install
and
service



The CLAS HE boiler has been designed with ease of installation in mind and the boiler features a simple connection kit, which includes a filling loop. And to ensure a tidy finish to the installation, CLAS HE also has a clip-on connection kit cover.

With the range of installation accessories available, it is possible to; pre-plumb and test the heating system before fitting the boiler, run the pipe work behind the boiler (using the optional rear piping chassis) and, through the plume management kit, offer more siting options.

Access to the boiler is straightforward and all components inside the boiler are easily reached.

The latest technology

Maximum comfort

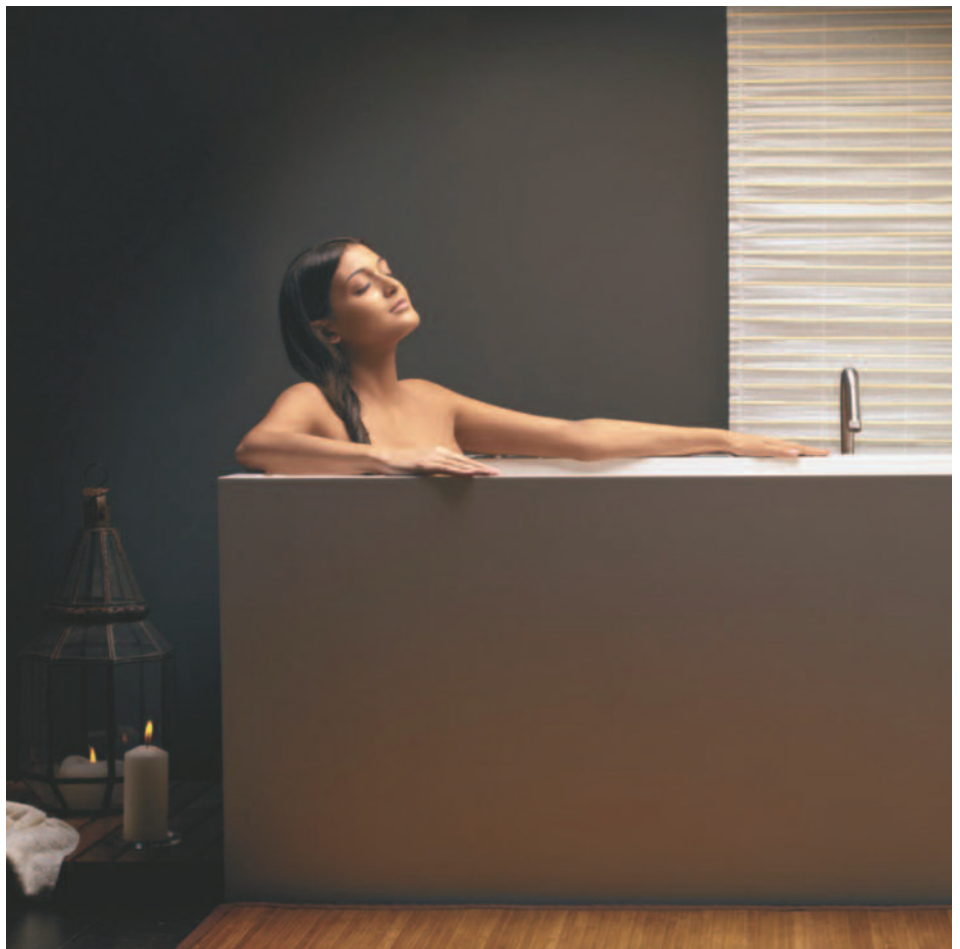
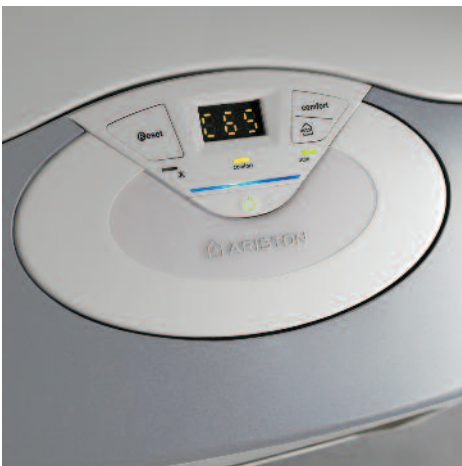

Easy installation, hassle free servicing

The CLAS HE range has been designed with the installer in mind. The dimensions between the pipe work connections and the flue has been reduced, allowing for a lower fixing height. The combi and system boiler versions feature a simple connection kit, which includes a filling loop as standard. All components are easily accessible and require a minimal amount of tools for servicing and maintenance.

Simple controls

There is an extensive selection of easy to use controls available for the CLAS HE range. The controls are available as both wired and wireless (allowing installation without the need for a qualified electrician).

These, in conjunction with the AUTO function, will enable the boiler to work at its most efficient to achieve the desired room temperature.

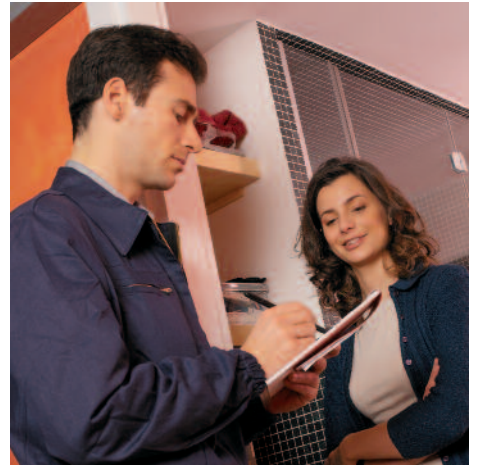

Stylish design and LCD display

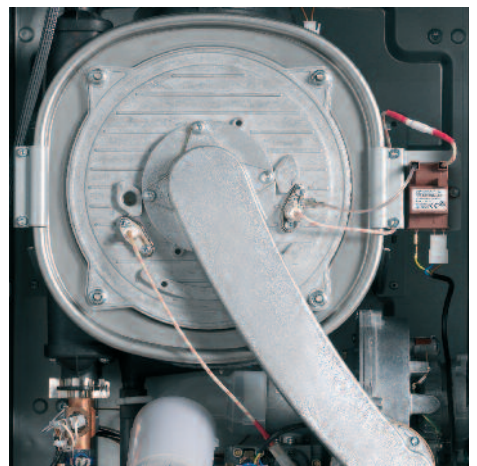

Installer benefits

- SEDBUK Band A
- Filling loop (combi and system versions)
- Mechanical time clock (combi versions)
- Rear piping chassis available as an option (combi and system versions)
- Reduced fixing height between pipe work and flue
- Multiple flueing options
- Easily accessible for servicing and maintenance
- Wide range of control and installation accessories available

Latest technology - The unique AUTO function

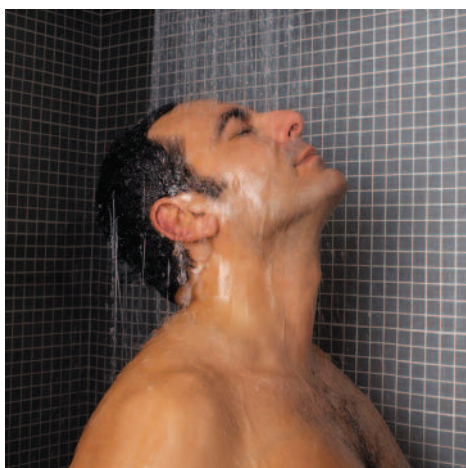

Customised
comfort,
unrivalled
performance

The advanced AUTO function ensures intelligent management of the room temperature whilst guaranteeing maximum energy efficiency and offering energy savings.

By pressing the AUTO button on the CLAS HE control panel, the boiler will automatically choose the ideal temperature for the central heating circuit by gradually increasing the temperature of the system water until the room reaches the set temperature, whilst guaranteeing no excessive peaks in the flow temperature.

When used in conjunction with the extensive range of controls, the AUTO function ensures greater levels of comfort and savings are achieved.

With the AUTO function activated and by fitting an outdoor sensor, together with the modulating room sensor, the highest level of efficiency can be achieved.

Programmable Room Thermostat

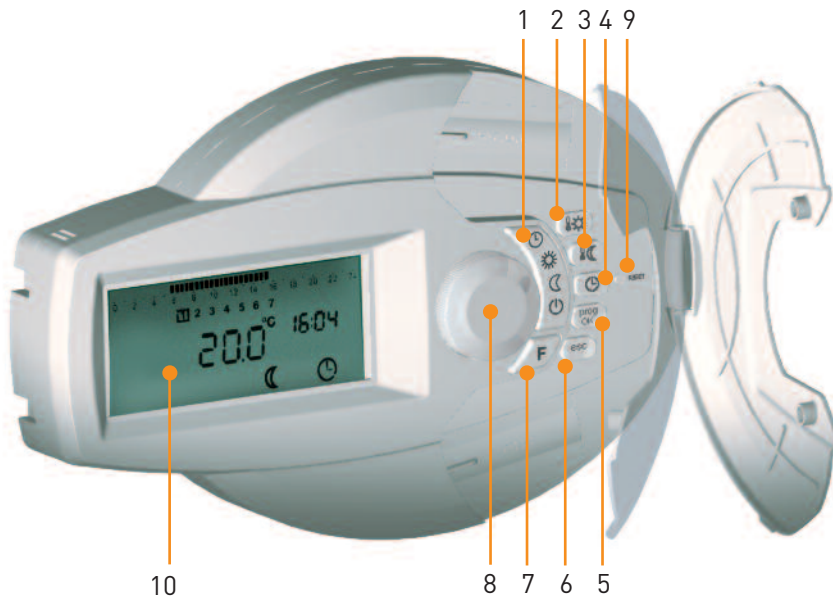

- | | |
|----------------------------------|--|
| 1. Function select button | 7. Special function button
(Party/Holiday etc.) |
| 2. Day time temperature button | 8. Multi-functional dial |
| 3. Night time temperature button | 9. Reset button |
| 4. Hour / date button | 10. Multi-functional display |
| 5. Programmer button | |
| 6. Escape button | |

Advanced,
intelligent
functions

Multi-functional
LCD interface

Ariston also offers an extensive range of temperature controls for use with the CLAS HE range.

These are available either as hard wired or wireless, and include on-off room thermostats, modulating room sensors, outdoor sensors and programmable room thermostats.

The wireless controls can be fitted without the need for a qualified electrician.

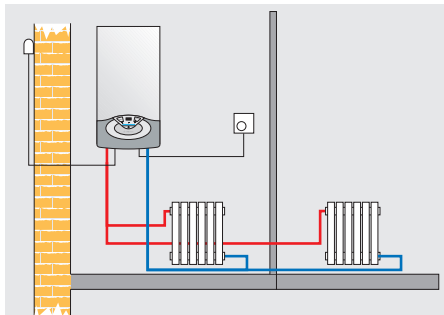

SINGLE-ZONE SYSTEMS

Heat control based on the external temperature (monitored by an outdoor sensor) and the internal temperature (controlled by a modulating room sensor).

Modulating Room Sensor
(wired/wireless)



Signal Receiver



Room Thermostat
(wired)



Outdoor Sensor
(wireless)



Outdoor Sensor
(wired)



CLAS HE COMBI

24 FF - 30 FF
38 FF

WALL-HUNG HIGH EFFICIENCY
GAS COMBINATION BOILERS

2 FREE
2 year
guarantee



COMPACT
DIMENSIONS



QUIET
OPERATION



AUTO



ENERGY
EFFICIENT

- SEDBUK BAND A
- AVAILABLE IN THREE OUTPUTS
- HIGH HOT WATER FLOW RATES
- COMPREHENSIVE RANGE OF WIRED AND WIRELESS CONTROLS
- UNIQUE 'AUTO' FUNCTION OPTIMISES EFFICIENCY OF BOILER AND SYSTEM
- COMFORT SWITCH (PRE-HEAT HOT WATER FUNCTION)

- AUTO-DIAGNOSTIC SYSTEM
- SIMPLE MAINTENANCE WITH ACCESS FROM THE FRONT OF THE APPLIANCE
- ANTI-FROST AND ANTI-SCALE DEVICE
- BUILT-IN AUTOMATIC BY-PASS
- BUILT-IN MECHANICAL TIME CLOCK
- INCLUDES CONNECTION KIT AND FILLING LOOP
- CLIP-ON CONNECTION KIT COVER AS STANDARD



band *A*
comfort function
energy saving

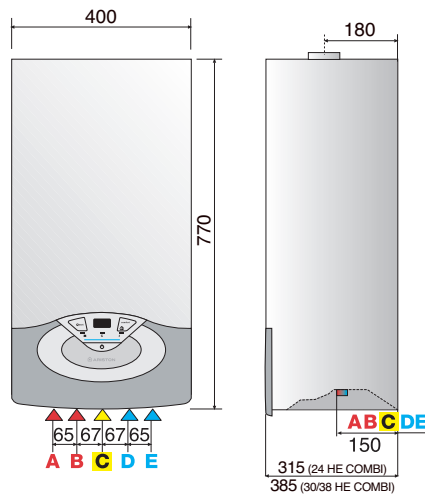

LEGEND

- A: Central heating flow 22mm compression
- B: Domestic hot water outlet 15mm compression
- C: Gas inlet 15mm compression
- D: Domestic hot water inlet 15mm compression
- E: Central heating return 22mm compression
- F: Flue (Ø mm)
F1: 60/100 - 80/125
F2: 80

Coaxial exhaust

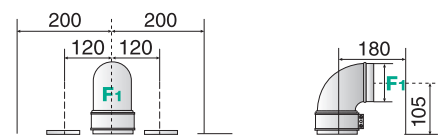

Ø60/100: up to 12m (24kW)
Ø80/125: up to 24m (24kW)

Twin pipe exhaust

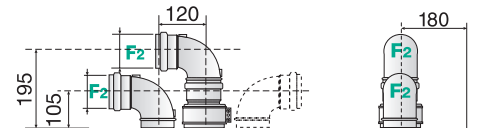

Ø80/80: up to 60m (24kW)

CLAS HE SYSTEM

18 FF - 24 FF
30 FF

WALL-HUNG HIGH EFFICIENCY
GAS SYSTEM BOILERS

2 FREE
2 year
guarantee



COMPACT
DIMENSIONS



QUIET
OPERATION



AUTO



ENERGY
EFFICIENT



- SEDBUK BAND A
- AVAILABLE IN THREE OUTPUTS
- COMPREHENSIVE RANGE OF WIRED AND WIRELESS CONTROLS
- UNIQUE 'AUTO' FUNCTION OPTIMISES EFFICIENCY OF BOILER AND SYSTEM
- AUTO-DIAGNOSTIC SYSTEM
- SIMPLE MAINTENANCE WITH ACCESS FROM THE FRONT OF THE APPLIANCE

- BUILT-IN AUTOMATIC BY-PASS
- INCLUDES CONNECTION KIT AND FILLING LOOP
- CLIP-ON CONNECTION KIT COVER AS STANDARD



band **A**
energy saving
extra safe **IPX5D**

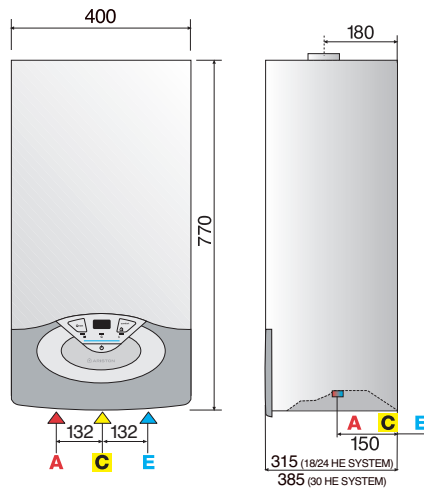

LEGEND

- A: Central heating flow 22mm compression
- C: Gas inlet 15mm compression
- E: Central heating return 22mm compression
- F: Flue (Ø mm)
- F1: 60/100 - 80/125
- F2: 80

Coaxial exhaust

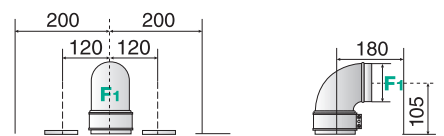

Ø60/100: up to 12m (24kW)
Ø80/125: up to 24m (24kW)

Twin pipe exhaust

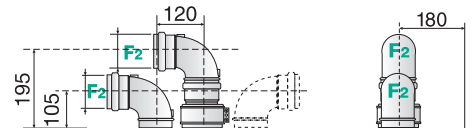

Ø80/80: up to 60m (24kW)

Technical Information

		CLAS HE SYSTEM 18 FF	CLAS HE SYSTEM 24 FF	CLAS HE SYSTEM 30 FF
EFFICIENCY				
SEDBUK Rating	Band	A	A	A
SAP efficiency	%	90.2	90.4	90.4
POWER & PERFORMANCE				
Heat input max.	kW-Btu/h	20.0 - 68,200	27.7 - 94,500	33.3 - 113,600
Heat input min.	kW-Btu/h	5.0 - 17,000	6.1 - 20,800	7.2 - 24,500
Heat output max. (C.H.)	kW-Btu/h	17.6 - 60,000	21.0 - 71,600	27.0 - 92,100
Heat output min.	kW-Btu/h	4.2 - 14,300	5.0 - 17,000	6.0 22,000
Central heating temp. max. (high temp.)	°C	82	82	82
Central heating temp. min. (high temp.)	°C	35	35	35
Central heating temp. max. (low temp.)	°C	45	45	45
Central heating temp. min. (low temp.)	°C	20	20	20
CHARACTERISTICS				
Minimum ambient temperature	°C	5	5	5
Built-in expansion vessel capacity	l	8	8	8
Built-in expansion vessel pre-charged	bar	0.7	0.7	0.7
Maximum water content of system	l	100	100	100
Maximum heating pressure	bar	3	3	3
Servicing clearances - top/front/bottom	mm	250/450/200	250/450/200	250/450/200
Servicing clearances - left/right	mm	5/5	5/5	5/5
Zero compartment ventilation		Yes	Yes	Yes
Weight	kg	31	32	35
ELECTRICAL DATA				
Electrical supply	V/Hz	230/50	230/50	230/50
Power consumption	W	105	114	115
Protection grade of electrical system	IP	X5D	X5D	X5D
Internal fuse rating		2A Fast Fuse	2A Fast Fuse	2A?Fast Fuse
PRODUCT CODE		3665073	3665070	3665071

Accessories

	Code
WIRED CONTROLS	
On/Off Room Thermostat	3318238
On/Off Programmable Room Thermostat	3318239
Modulating Room Sensor	3318331
Outdoor Sensor	3318232
BUS Interface	3318229
WIRELESS CONTROLS	
On/Off Programmable Room Thermostat	3318241
Receiver (On/Off Controls)	3318240
Modulating Room Sensor	3318235
Outdoor Sensor	3318236
Receiver (Modulating Controls)	3318233
Repeater (Modulating Controls)	3318237
BUS Interface	3318229
GENERAL ACCESSORIES	
Rear Piping Chassis	3678411
Metal Template	3318246
Pre-Installation Kit	3678353

*highly
adaptable*

Graph of boiler residual head $\Delta T 20^{\circ}\text{C}$
1 High Speed
2 Low Speed

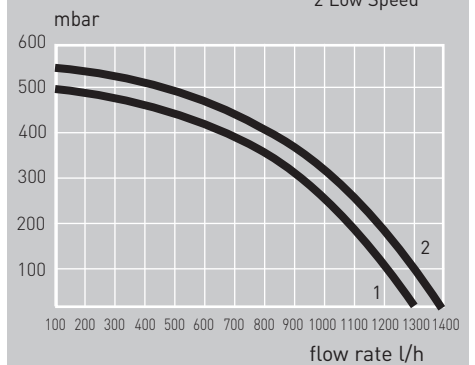

ROOM SEALED FAN FLUE

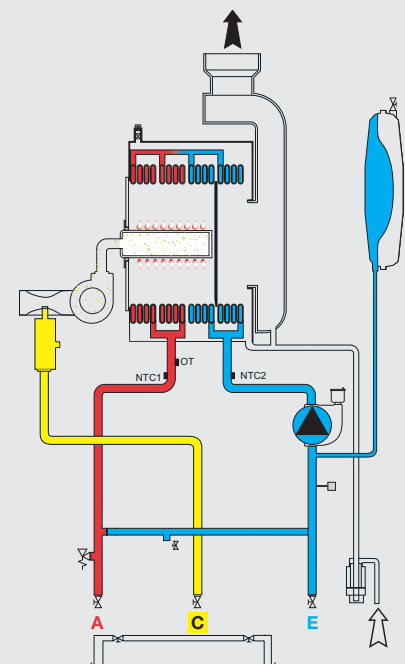

CLAS HE R

12 FF - 18 FF
24 FF

WALL-HUNG HIGH EFFICIENCY
GAS REGULAR BOILERS

2 FREE
2 year
guarantee



COMPACT
DIMENSIONS



QUIET
OPERATION



AUTO



ENERGY
EFFICIENT

- SEDBUK BAND A
- AVAILABLE IN THREE OUTPUTS
- UNIQUE 'AUTO' FUNCTION OPTIMISES EFFICIENCY OF BOILER AND SYSTEM
- AUTO-DIAGNOSTIC SYSTEM
- SIMPLE MAINTENANCE WITH ACCESS FROM THE FRONT OF THE APPLIANCE
- ANTI-FROST PROTECTION

- FOR USE ON OPEN VENTED AND SEALED SYSTEMS
- SEALED SYSTEM KIT AVAILABLE AS AN OPTIONAL EXTRA
- COMPREHENSIVE RANGE OF WIRED AND WIRELESS CONTROLS
- 240V SWITCHING



band **A**
energy saving

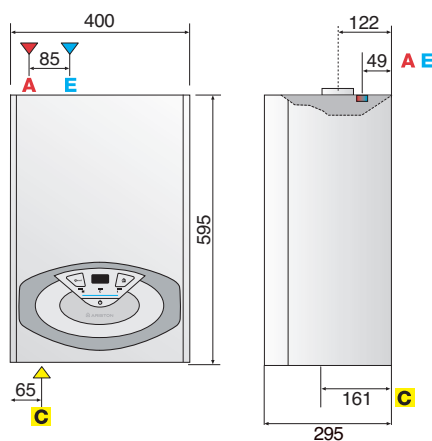

LEGEND

- A: Central heating flow 22mm compression
- C: Gas inlet 15mm compression
- E: Central heating return 22mm compression
- F: Flue (Ø mm)
- F1: 60/100 - 80/125
- F2: 80

Coaxial exhaust

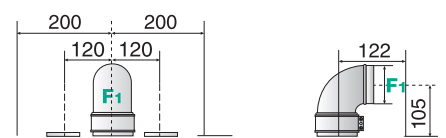

Ø60/100: up to 12m (24kW)
Ø80/125: up to 24m (24kW)

Twin pipe exhaust

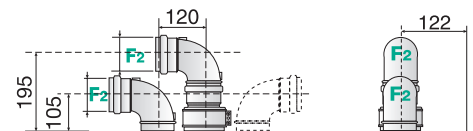

Ø80/80: up to 60m (24kW)

Technical Information

		CLAS HE R 12 FF	CLAS HE R 18 FF	CLAS HE R 24 FF
EFFICIENCY				
SEDBUK Rating	Band	A	A	A
SAP efficiency	%	90.2	90.4	90.4
POWER & PERFORMANCE				
Heat input max.	kW-Btu/h	12.0 - 40,900	20.0 - 68,200	22.0 - 75,000
Heat input min.	kW-Btu/h	3.0 - 10,200	5.0 - 17,000	5.5 - 18,800
Heat output max. (C.H.)	kW-Btu/h	11.7 - 40,000	17.6 - 60,000	21.6 - 73,700
Heat output min.	kW-Btu/h	2.8 - 9,500	4.2 - 14,300	5.2 - 17,700
Central heating temp. max. (high temp.)	°C	82	82	82
Central heating temp. min. (high temp.)	°C	35	35	35
Central heating temp. max. (low temp.)	°C	45	45	45
Central heating temp. min. (low temp.)	°C	20	20	20
CHARACTERISTICS				
Minimum ambient temperature	°C	5	5	5
Servicing clearances - top/front/bottom	mm	250/450/200	250/450/200	250/450/200
Servicing clearances - left/right	mm	5/5	5/5	5/5
Zero compartment ventilation		Yes	Yes	Yes
Weight	kg	32	32	32
ELECTRICAL DATA				
Electrical supply	V/Hz	230/50	230/50	230/50
Power consumption	W	87	105	114
Protection grade of electrical system	IP	X4D	X4D	X4D
Internal fuse rating		2A Fast Fuse	2A Fast Fuse	2A Fast Fuse
PRODUCT CODE		3665086	3665087	3665088

Accessories

	Code
HYDRAULIC ACCESSORIES	
Sealed System Kit	3678458
WIRED CONTROLS	
On/Off Room Thermostat	3318238
Modulating Room Sensor	3318331
Outdoor Sensor	3318232
Twin Channel Digital Programmer	3318412
BUS Interface	3318229
WIRELESS CONTROLS	
Receiver (On/Off Controls)	3318240
Modulating Room Sensor	3318235
Outdoor Sensor	3318236
Receiver (Modulating Controls)	3318233
Repeater (Modulating Controls)	3318237
BUS Interface	3318229
Twin Channel Digital Programmer	3318413

*totally
versatile*

ROOM SEALED FAN FLUE

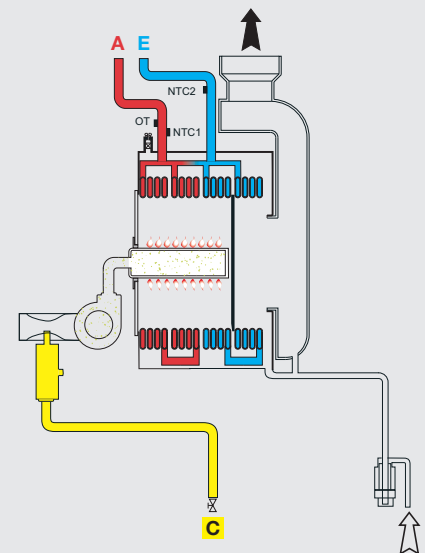

Flue pipe accessories- Easy installation with unrivalled flexibility

Ariston boilers are designed to be completely adaptable to every possible flue situation that may be encountered during installation. The need for alteration to flue components is almost completely eliminated, making installation of the boiler quick and easy. It is possible to site flue terminals in a variety of positions in accordance with BS5440-1:2000.

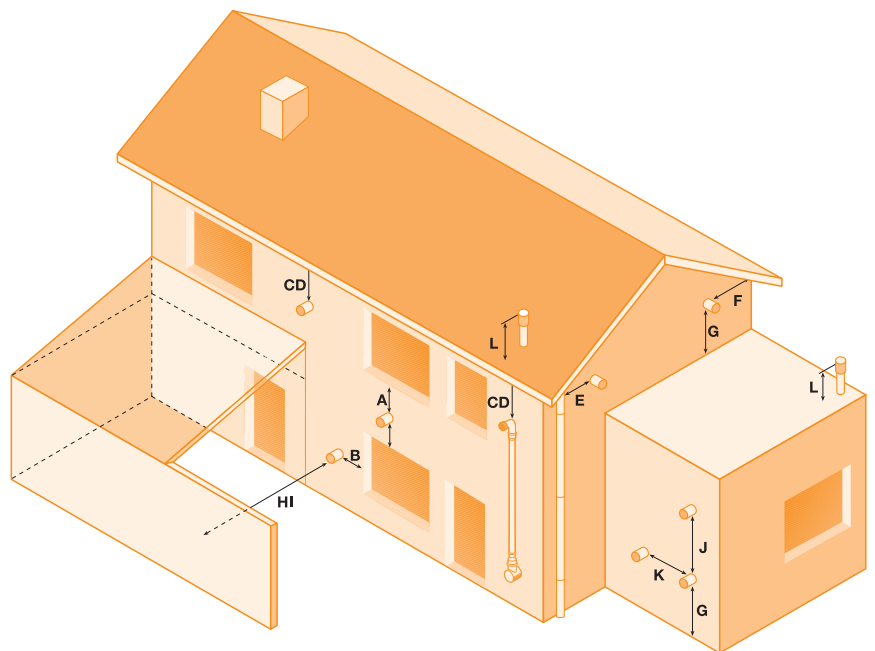

Installation conditions

TERMINAL POSITION

TERMINAL POSITION	mm	
A	Directly above/below an opening, air brick, opening windows, etc	300
B	Horizontally to an opening, air brick, opening windows, etc	300
C	Below gutters, soil pipes or drain pipes	75
D	Below eaves	200
E	From vertical drain or soil pipe	75
F	From an internal or external corner	300
G	Above ground roof or balcony level	2100
H	From a surface facing the terminal	2500
I	From a terminal facing the terminal	2500
J	Vertically from a terminal on the same wall	1500
K	Horizontally from a terminal in the same wall	300
L	Fixed by use of terminal and matched flashing plate	-

NOTE

- Do not install in a place likely to cause a nuisance/damage/discolouration
- Carport installations not acceptable with HE appliances
- Products should not cross property boundaries (2.5 metres)

TYPE 1 Coaxial System

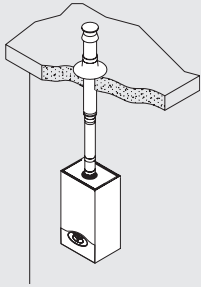

Vertical installation with coaxial piping on a flat roof.

TYPE 2 Coaxial System

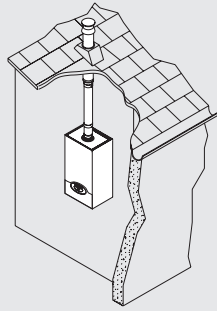

Vertical installation with coaxial piping on a pitched roof.

TYPE 3 Coaxial System

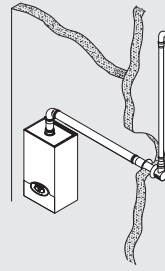

Horizontal installation with coaxial piping utilising a plume kit.

TYPE 4 Twin pipe system

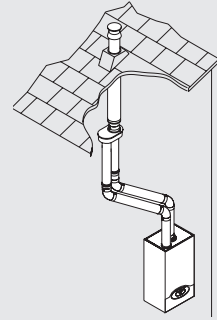

Installation with two separate pipes - exhaust and air inlet on a pitched roof via a coaxial adaptor.



Flue accessories

COAXIAL

OUR REF DESCRIPTION

- 3318073 Horizontal coaxial kit Ø 60/100 - 1000mm
- 3318329 Plume kit
- 3318075 90° Coaxial Elbow Ø 60/100
- 3318076 45° Coaxial Elbow Ø 60/100 (pack of 2)
- 3318077 Coaxial Extension Ø 60/100 - 1000mm
- 3318078 Coaxial Extension Ø 60/100 - 500mm
- 3318079 Vertical starter
- 3318090 Horizontal coaxial kit + adaptor Ø 80/125
- 3318091 90° Coaxial Elbow Ø 80/125
- 3318092 45° Coaxial Elbow Ø 80/125
- 3318093 Coaxial Extension Ø 80/125 - 1000mm
- 3318094 Coaxial Extension Ø 80/125 - 500mm
- 3318095 Adaptor 60/100-80/125

TWIN PIPE

OUR REF DESCRIPTION

- 3318082 Adaptor (Ø 60/80mm) for twin pipe systems
- 3318083 Twin pipe flue kit
- 3318084 90° MF Elbow (Ø 80mm) for twin pipe system
- 3318085 45° MF Elbow (Ø 80mm) for twin pipe system (pack of 2)
- 3318086 Pipe - 1000mm (Ø 80mm) for twin pipe systems

TWIN PIPE

OUR REF DESCRIPTION

- 3318087 Pipe - 500mm (Ø 80mm) for twin pipe systems
- 3318088 Adaptor 80/125 - 80

- 3318089 Adaptor 80/125 - 80+80
- 3318027 Stainless steel exhaust vent cap (Ø 80mm)
- 3318028 Intake vent cap

SUNDRY ITEMS

OUR REF DESCRIPTION

- 3318009/ Lead Flashing Base
- 3318010 Cap Black/Red
- 3318011/ Vent Cap Base for
- 3318012 Flat Roof Black/Red
- 3318080/ Standard Vertical Flue with
- 3318081 Terminal (Black/Red)
- 3318015 Wall Bracket Kit
- (Ø 80mm - Ø 125) (pack of 3)
- 3318016 Cover Plate (Ø 100)

ARISTON THERMO GROUP

Ariston Thermo UK Ltd
Ariston Building
Hughenden Avenue
High Wycombe
Bucks HP13 5FT
Telephone 01494 755600
Fax 01494 459775

Technical Advice & Customer Service
Fax 01494 463066
techhelpdesk.uk@aristonthermo.com
info.uk@aristonthermo.com

www.ariston.co.uk

Professional Team Limited
Plaza 256
Blanchardstown Corporate Park 2
Ballycoolin
Dublin 15
Telephone 01 899 1500
Fax 01 899 1501

Technical Advice & Customer Service
Fax 01 899 1501
techhelpdesk.ie@aristonthermo.com
info.ie@aristonthermo.com

www.aristonthermo.ie

