

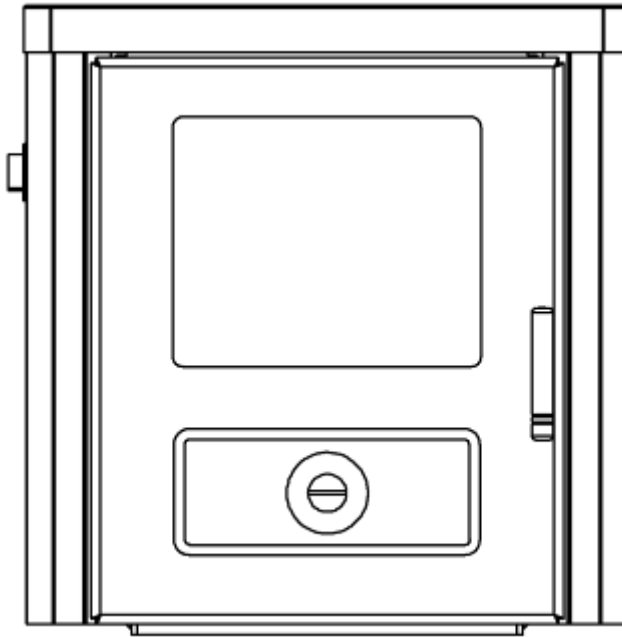

TRH 45 MK4
SOLID FUEL ROOM HEATER



**USER AND INSTALLATION
INSTRUCTIONS**

To be retained by the householder

HEALTH AND SAFETY

INFORMATION FOR THE INSTALLER AND SERVICE ENGINEERS

Under the Consumer Protection Act 1987 and the Health And Safety At Work Act 1974, it is a requirement to provide information on substances hazardous to health (COSHH Regulations 1988).

TR Engineering takes every reasonable care to ensure that these products are designed and constructed to meet these general requirements, when properly used and installed.

To fulfil this requirement products are comprehensively tested and examined before despatch.

This appliance may contain some of the items below.

When working on the appliance it is the users/engineers responsibility to ensure that any necessary personal protective equipment is worn appropriate to parts that could be considered as being hazardous to health and safety.

INSULATION AND SEALS

Glass Rope, Mineral Wool, Insulation Pads, Ceramic Fibre and Glass Insulation.

May be harmful if inhaled. May be irritating to the skin, eyes nose or throat. When handling avoid inhalation and contact with eyes. Use disposable gloves, facemasks and eye protection.

After handling wash hands and other exposed parts. When disposing, reduce dust with water spray, ensure parts are securely wrapped.

GLUES, SEALANTS AND PAINTS

Glues, sealants and paints are used in this product and present no known hazards when used in the manner for which they are intended.

IMPORTANT

AS PART OF BUILDING REGULATIONS PART J OCTOBER 2010, IT IS A REQUIREMENT THAT A CARBON MONOXIDE DETECTOR IS FITTED IN THE ROOM WHICH HOUSES THE APPLIANCE.

CONTENTS

	Page
1. USER INSTRUCTIONS	4
Fuels to Use	4
Operating Tool	4
Lighting	4
Control Settings	4
Refuelling	4
Ash Removal	4
Overnight Burning	4
To Revive the Fire	4
2. CLEANING	5
Enamelled Parts	5
Chimney Sweeping	5
Grate Removal	5
Shaker Rod Removal	5
3. MAINTENANCE	5
Shutting Down	5
Assembly	6-8
4. INSTALLATION INSTRUCTIONS	9
General Description	9
Specification	9
Installation	9
Central Heating System	9
Domestic Hot Water System	10
Air Supply	10
Chimney Requirements	10
Flue Connections	11
Fireplace Recess	11
Fireplace Surround	11
Door Location	11
Boiler Location	11
Casing Assembly	11
User Guidance	11
5. BOILER DIMENSIONS	12
7. PERFORMANCE GRAPH	12

USER INSTRUCTIONS

Fuels to use:

Sunbrite Singles and Doubles
Small size Rexco.
Coalite.
Anthracite Stove Nuts.
Welsh Dry Steam Coal Small Nuts.
COAL SHOULD NOT BE USED.
PETRO COKE MUST NOT BE USED ON THIS APPLIANCE.

Operating Tool

A multi-purpose tool is supplied with the appliance for the removal of the ash-pan, operation of the shaker grate and door catch.

Lighting

1. Place wood and paper or firelighters on grate as for an open fire. Cover with a small amount of fuel and light.
2. When fire is established, add more fuel up to the level of the front fire bars, sloping up to the back. Do not overfill or allow pieces of fuel to become trapped between front bars and door as this could crack the glass.
3. Close fire door and firmly latch.
4. Set thermostat control knob to the required setting. (See under 'Control Settings' for guidance).

Control Settings

The rate of burning is regulated by the control knob at the top left-hand side of the frame surround.

The required setting will usually be found by experience, since many factors can affect the chosen position, such as the weather conditions, chimney draught and the comfort conditions required. However, the following settings can be used as a guide:

Mid-winter	Setting 3 to 4
Early and latter parts of the heating season	Setting 2 to 3
Domestic hot water only	
Overnight burning	

If the fire goes out open idling air disc to slightly increase the burning rate. See Fig. 1

Refuelling

1. Do not allow the fire to burn too low before refuelling.
2. With the door closed, clear ash from the grate by inserting tool in end of shaker bar and operate sharply up and down.
3. Add fuel to the level of the front fire bars, sloping it upwards to the back of the fire box.
4. Firmly latch the fire door.

IMPORTANT

WHEN DE-ASHING AND REFUELLING THE BOILER A HEAT RESISTANT GLOVE MUST BE WORN WHEN OPENING AND CLOSING THE DOOR.

Ash Removal

The frequency is dependent upon the rate of burning, but once a day should normally be sufficient.

Note: It is important that ash is not allowed to build up to the underside of the grate otherwise the bars could be damaged.

To remove the ash, open the fire door and draw out the ash pan with the multi-purpose tool and carry it outside with the aid of the carrying handle.

Overnight Burning

With the control knob set at No. 2 to 3 the appliance can be left for long periods without attention.

1. Clear the fire bed of ash by operating the shaker grate and empty the ash pan if necessary.
2. Fill the firebox to the level of the front bars, sloping backwards and upwards towards the rear of the appliance.
3. Close the door and firmly latch.

To Revive the Fire

1. Shake the grate to clear the ash.
2. Refuel.
3. Adjust the control knob to a high setting.

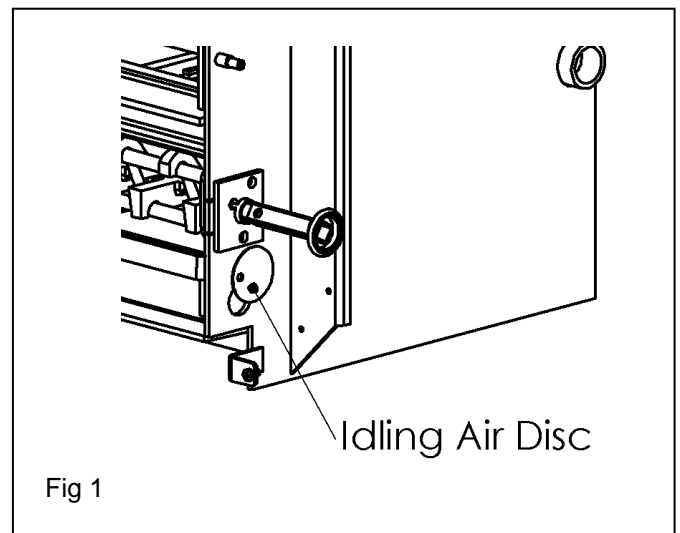

CLEANING

The glass in the fire door has special heat resisting qualities and will adequately withstand the operating temperatures reached by the appliance. However, it must be remembered that glass is fragile and care must be taken to avoid rough treatment, which could lead to breakage. Cleaning should be carried out regularly to avoid discolouration. **DO NOT CLEAN WHILST HOT.** Open door and allow glass to cool before wiping with a damp cloth.

Note: Should replacement glass be required, this can be obtained from your local Builders' Merchant.

Painted Parts

When the appliance is cool, wipe the surfaces with a damp cloth. **DO NOT ATTEMPT TO CLEAN WHILST APPLIANCE IS HOT, NOR USE ABRASIVE CLEANERS.** Finally polish with a soft cloth.

Flue Cleaning

It is necessary to hinge down the throat plate monthly so as to clear any flue deposits from the plate and flue outlet. To achieve this, locate the operating tool in the cutout at the front of the throat plate. Lifting slightly and pulling forward the throat plate will be released and can be lowered into its cleaning position (See Fig. 2). Scrape or brush all deposits from the throat plate and flue outlet. Replace throat plate ensuring it is correctly located.

Chimney Sweeping

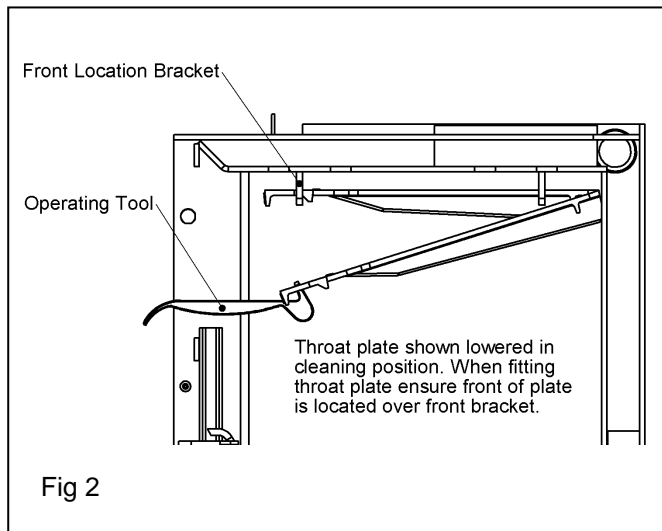

Where the chimney is believed to have served an open fire installation it is possible that the higher flue gas temperatures from a room heater may loosen deposits that were previously firmly adhered, with consequent risk of flue blockage. It is therefore recommended that the chimney be swept a second time shortly after the room heater has commenced operation. The chimney should be swept annually to ensure that a complete evacuation of flue gases is always possible. This can be carried out through the fire opening after having removed the throat plate. Remember to remove any deposits from the top of the boiler before replacing throat plate. Flexible chimney sweeping rods should be used to facilitate cleaning.

Grate Removal

This appliance is fitted with a reciprocating shaker grate having ten individual bars fitted alternately on two rods, five bars with short-necked hooks on the lower rod and five bars with long necked hooks on the upper rod.

To remove, lift out deepening bar and fire front plate, bring the bottom rod in the forward position, lift each bar upwards, push to the rear until clear of the rod and withdraw. When all bottom bars have been removed, bring the upper rod forward and repeat as for the lower bars. Refit bars in the reverse order.

Note: Ensure that the bars are placed alternately and that the short-necked bars are on the lower rod and the long necked ones on the upper rod. The rear of the bars is supported on a bracket at the back of the boiler.

Replace the fire front plate, the base must rest in the 'U' brackets to keep it clear of the fire bars (See Fig. 3). The deepening bar can now be fitted above it in the retaining guides.

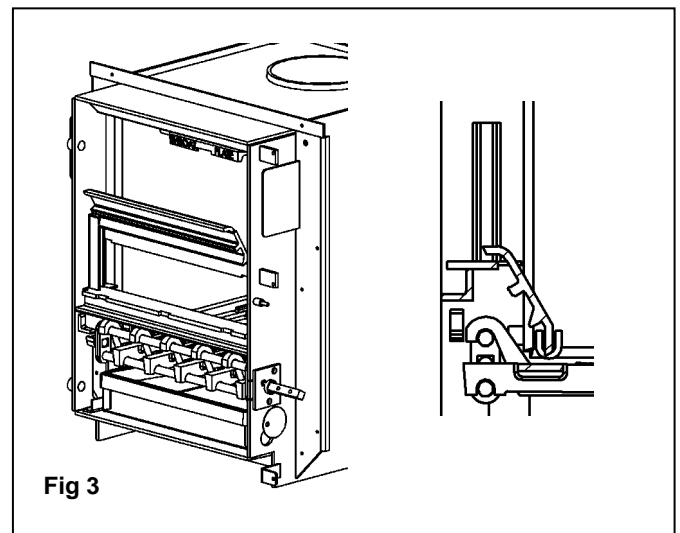

Shaker Rod Removal

Remove the two fixing screws holding the small plate on the right-hand side of the boiler and withdraw shaker rod.

Maintenance

SHUTTING DOWN

When letting the fire out for the summer months or for any other prolonged period the following procedure should be carried out:

1. Remove all fuel from firebox and empty ash can.
2. Remove throat plate and front fire bars and thoroughly scrape all internal surfaces of firebox.
3. To guard against corrosion it is recommended that all surfaces of firebox are sprayed or brushed with an anti-corrosion treatment.
4. As a further safeguard against corrosion leave the fire door partially open to ensure good ventilation of the appliance.

WARNING

Before re-lighting the appliance and in particular at the start of the heating session it is important to check the flue outlet has not become blocked by a fall of deposits from the chimney. Remove throat-plate in order to make a thorough check.

When properly installed and operated this stove will not emit fumes. Occasional fumes from de-ashing and re-fuelling may occur but persistent fume emission must not be tolerated. If the fume emission does persist then the following immediate actions must be taken: -

- (a) Open all doors and windows to ventilate the room.
- (b) Let the fire out or safely dispose of the burning fuel.
- (c) Check for flue or chimney blockage and clean as necessary.
- (d) Do not attempt to relight the stove until the cause of the fume emission has been remedied. If necessary seek professional advice.

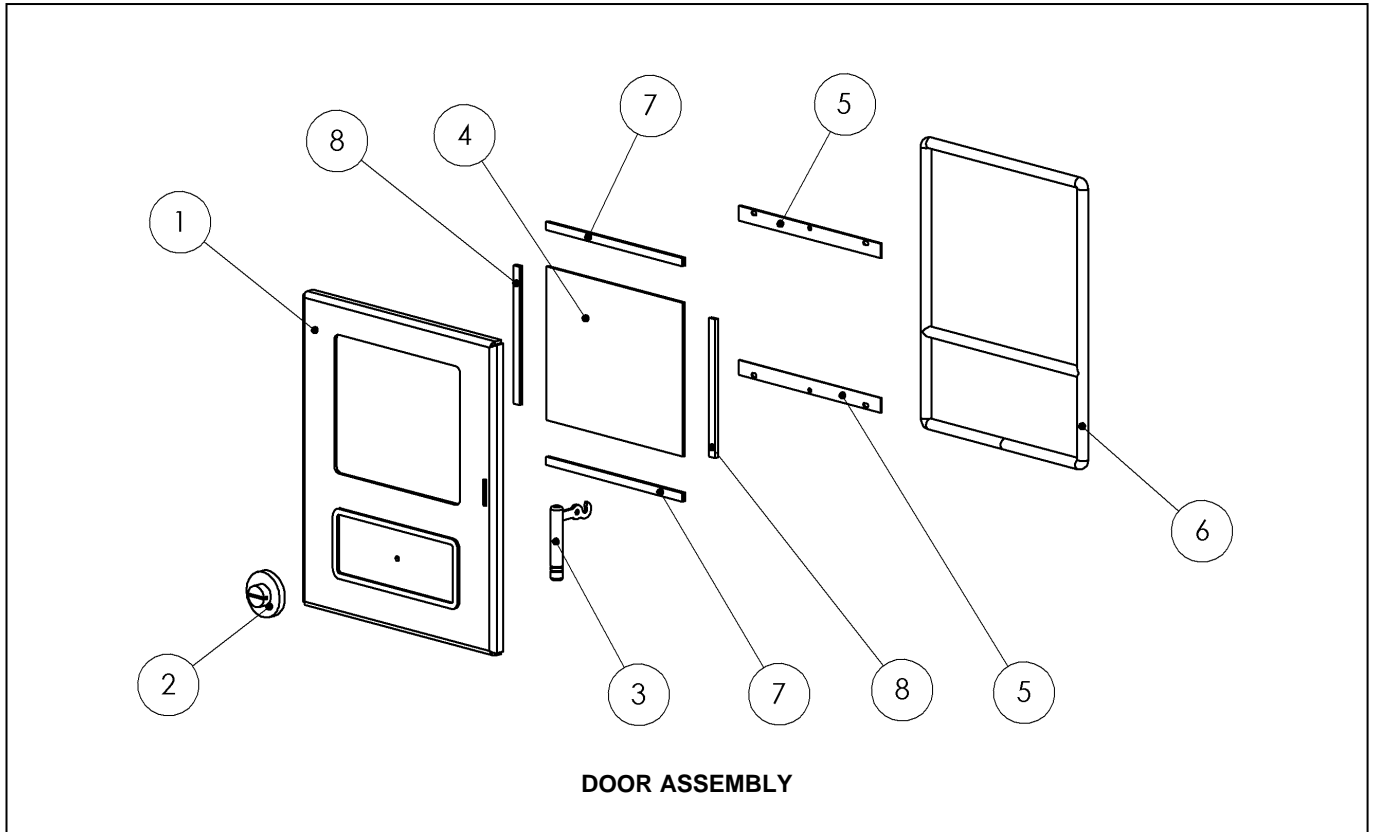

Item No	Part No	Description	No Off
1	700620	DOOR W.U. PTD	1
2	700216	DOOR SPINNER	1
3	700345	DOOR HANDLE W.U.	1
4	700616	DOOR GLASS	1

Item No	Part No	Description	No Off
5	700635	GLASS FIXING BRACKET	2
6	98175	GLASS FIBRE ROPE	2mtr
7	700617	DOOR GLASS SEAL TOP	2
8	700618	DOOR GLASS SEAL SIDE	2

Size in mm unless otherwise stated

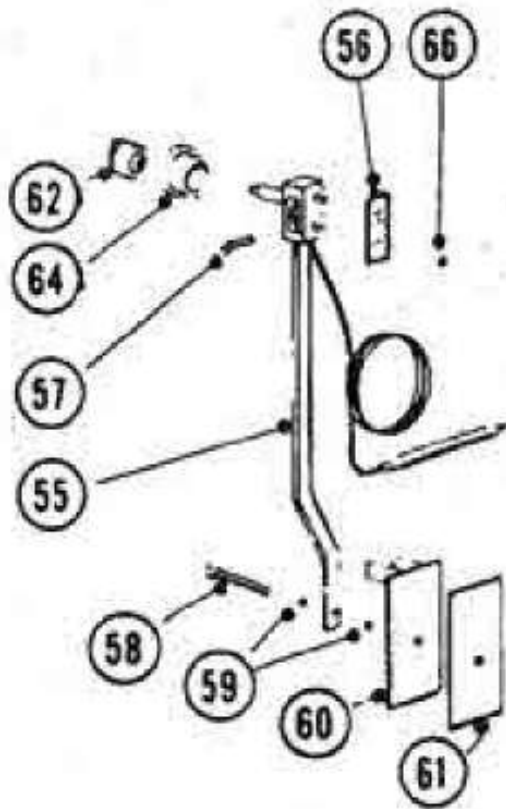

AIR CONTROL ASSEMBLY

Item No	Part No	Description	No Off
	32750	AIR CONTROL ASSEMBLY	1
55	32751	Thermostat, Rathgeber or Teddington	1
56	32752	Thermostat Fixing Bracket	1
57	91184	MX5X10 Pan Hd Pozi Setscrew	2
58	91321	M5X50 Pan Hd Pozi Setscrew	1
59	94216	M5 Hex Nut	2

Item No	Part No	Description	No Off
60	32753	Air Control Flap W.U.	1
61	32756	Flap Gasket	1
62	32786	Control Knob	1
64	32758	Shroud, Brown	1
66	94261	M4 But, Full	2

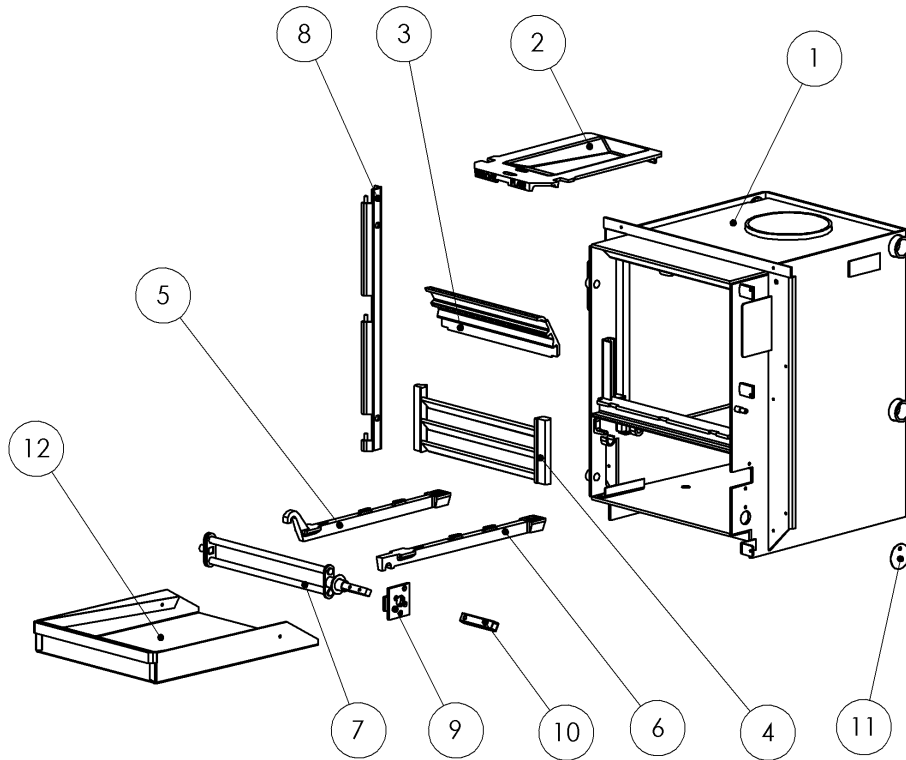

BOILER BODY ASSEMBLY

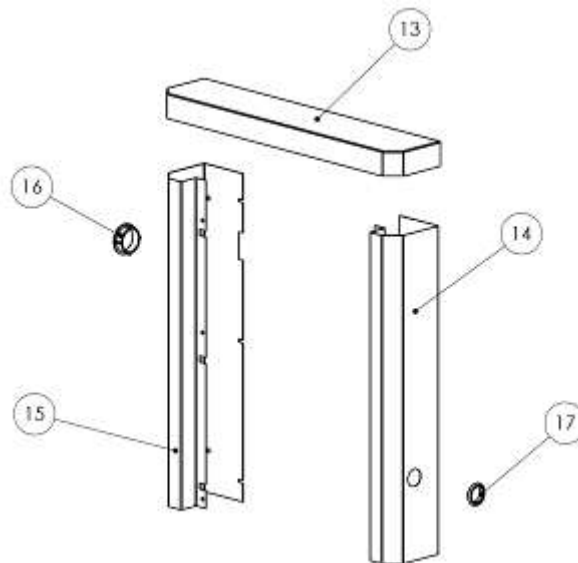

SURROUND ASSEMBLY

Item No	Part No	Description	No Off
	30500	COMPLETE BOILERBODY ASSY,TRH45	1
1	30510	BODY BOILER W.U. TRH45 Mk 3	1
2	32878	THROAT PLATE (MK 1 & MK 2)	1
3	30525	THROAT PLATE (MK 3)	1
4	32512	FIRE FRONT PLATE	1
5	32553	DEEPENING BAR	1
6	32545	FIRE BAR (B)	5
7	32544	FIRE BAR (A)	5
8	32460	SHAKER BAR ASSEMBLY	1

Item No	Part No	Description	No Off
9	91021	M5X12 PAN HD POZI SETSCREW	4
10	32661	DOOR PIN	1
11	94257	M8 HEX NUT FULL	1
12	32649	IDLING AIR DISC	1
13	91172	M5X10 HEX HD SETSCREW	1
14	32463	EXTENSION TUBE	1
15	91088	M16X16 HEX HD SETSCREW	1
16	92199	M6 WASHER	1
17	32796	OPERATING TOOL	1

INSTALLATION INSTRUCTIONS

GENERAL DESCRIPTION

TR Engineering TRH Range of Room heaters has been approved by the DSFAAS for burning smokeless solid fuels and is in the list of Approved Domestic Solid Fuel Appliances issued by The Solid Fuel Advisory Service and The Solid Smokeless Fuels Federation.

COALS MUST NOT BE USED

The appliances are suitable for installation in a living room fireplace or can be supplied as a freestanding unit for fitting in the kitchen where they will provide full central heating and domestic hot water for a wide range of properties. The output or burning rate is regulated by a thermostatically controlled air damper which modulates between open and closed to maintain the selected water temperature.

The room heater can be connected to any normal type of heating and indirect hot water system but as they are continuously burning appliances it is essential that the domestic hot water is arranged for gravity circulation.

SPECIFICATION

The boiler is designed to BS.3378 and is constructed from electrically welded steel plate suitably braced for a system-working head of 15.8m (52 ft.) max.

Four 1" B.S.P. sockets are provided for connecting the heating and hot water circuits, two on each side of the boiler, and a deep top flue socket is provided for a 125mm (5") dia. flue-pipe connection.

The appliance has a one-piece mild steel door with a special rope gasket for sealing both charging throat and ash-pit areas. The back surround provided is finished in heat resisting black paint.

The grate comprises individual reciprocating chrome iron bars and de-ashing can be carried out with the door closed using the multi-purpose tool provided.

INSTALLATION

General

Before installing the appliance these instructions should be carefully read and complied with. The installer must also be satisfied that the appropriate sections of the following Standards; Codes of Practice and Regulations are observed: -

BS 8303 1986 – Code of Practice for installation of domestic heating and cooking appliances burning solid mineral fuels

BS 6461:1984 Pt. 1 – Code of Practice for masonry chimneys and flue pipes

BS 6461:1984 Pt. 2 – Code of Practice for factory made insulated chimneys and for internal application.

BS 5449:1977 – Forced circulation hot water systems.

The Building regulations.

Local Authority Bye Laws.

Local Water Authority Bye Laws.

The installer should be aware of his responsibility under the Health and safety at Work Act 1974 and provide appropriate protection for persons carrying out the installation work, particularly with regard to protection and caustic effect of fire cement and asbestos dust in existing installations.

CENTRAL HEATING SYSTEM

The central heating system may be either pumped small bore or gravity circulation employing radiators, skirting heating, blown convectors or any other suitable heat emitters. It is essential, however, that the domestic hot water circuit and bathroom radiator are arranged for gravity circulation as indicated under "Domestic Hot Water System" A drain-cock should be fitted at the lowest point of the system and a safety-valve incorporated in the pipe-work adjacent to the boiler flow.

Where it is not possible to fit a heat leak radiator in the gravity circuit as might be the case when installing in flats and bungalows, it is recommended that a high limit thermostat is fitted to the flow pipe to bring on the heating pump in the event of excess water temperature.

As the direct heat emission from the appliance has been kept to a minimum it may be necessary to fit a radiator in the same room as the appliance to provide an adequate standard of heating. The room heating outputs and radiators areas are listed under "Technical Data"

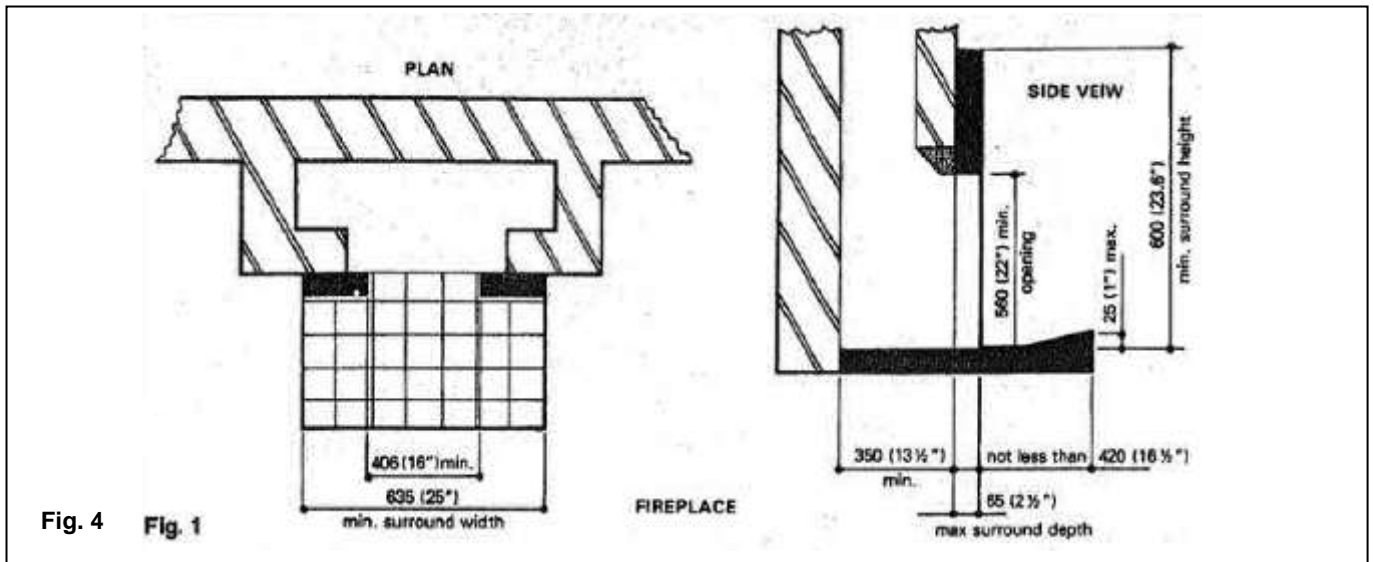

Fig. 4

Fig. 1

FIREPLACE

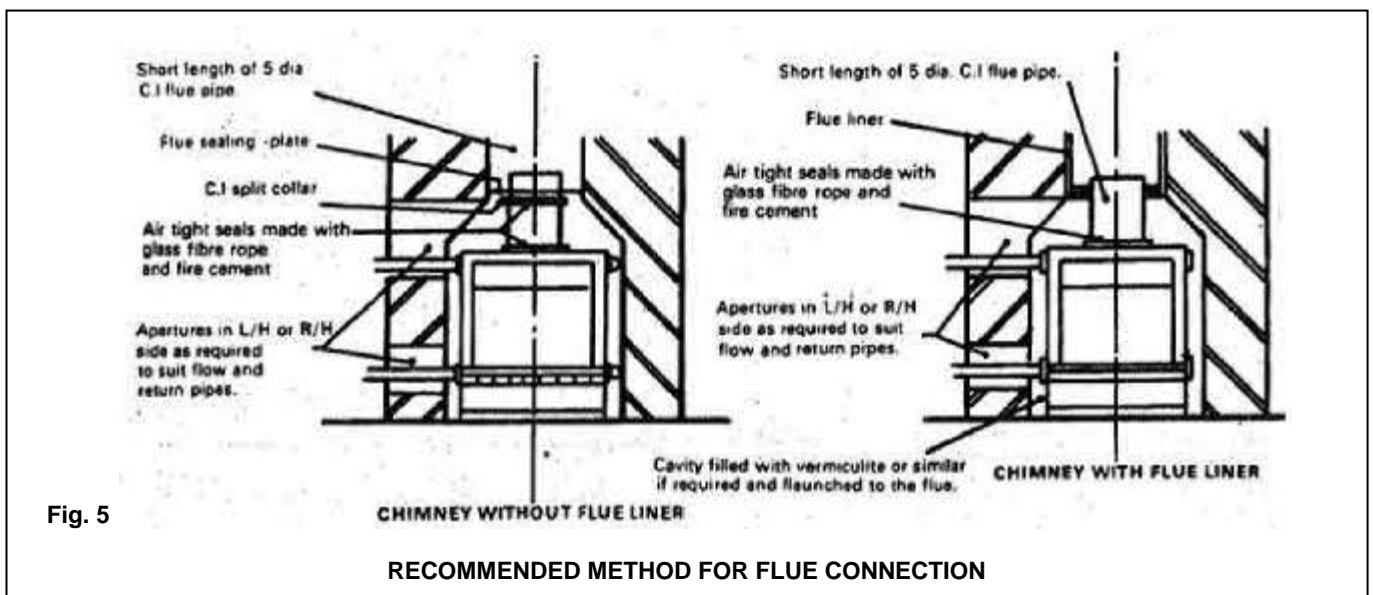

Fig. 5

CHIMNEY WITHOUT FLUE LINER

CHIMNEY WITH FLUE LINER

RECOMMENDED METHOD FOR FLUE CONNECTION

Domestic Hot Water System

It is essential that a double feed indirect cylinder complying with BS. 1566:Part 1 is used for a domestic hot water supply. No responsibility will be accepted by TR Engineering Limited if connected otherwise.

Connecting pipe-work should be at least 28mm. (1") dia. and the vertical distance between the thermal centres of the boiler and cylinder must not be less than 0.9m (3 ft.) to ensure good gravity circulation.

Note: - The primary circuit must not be fitted with a thermostatic valve or any other form of valve that could restrict the natural gravity circulation.

Air Supply

Adequate ventilation is required to ensure that sufficient air is available for combustion. The room in which the appliance is installed must be provided with a permanent fresh air opening of not less than 100cm² (16ins²) or alternatively other measures can be taken to ensure that

there is always adequate supply of air to the room from adjacent rooms or passages.

An extractor fan must not be used on the same room as the appliance.

Chimney Requirements

The chimney must be structurally sound and conform to the requirements of BS. 6461. The cross sectional area should not be excessive e.g. greater than 230mm x 230mm (9in x 9in). Expert advice should be sought if in doubt about the suitability of the chimney.

The Chimney must be swept clean prior to installation of the appliance and if the chimney has previously served an open fire the user must be advised to have the flue swept again after one month of regular use.

The chimney should not be subject to downdraught nor be fitted with a capping which could impede the discharge of flue gasses.

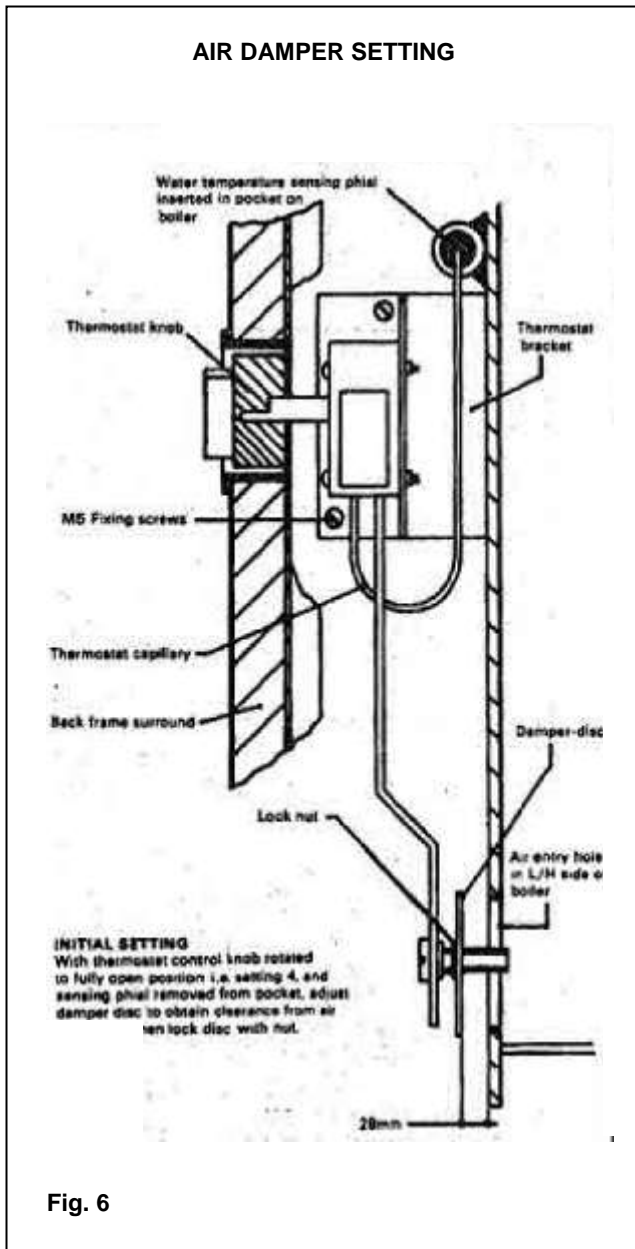

Flue Connection (see Fig. 5)

The room heater should be treated as a free standing appliance and connected to the chimney with a short length of 125mm (5") dia. cast iron flue-pipe and positively sealed at its top and bottom joints. Two suggested methods for flue connection are shown in Fig 2.

Fireplace Recess (see Fig. 4)

The brickwork recess must not be less than 350mm. (13 ½") deep x 560mm. (22") high x 406mm (16") wide. Openings must be left in one or both sides of the chimneybreast for pipe-work connectors and flue-pipe seating.

Fireplace Surround (see Fig. 4)

A minimum surround opening of 406mm wide x 560mm. High (16" x 22") is required with a maximum protection of 65mm. (2 ½). The surround must have a flat face of not less than 635mm. (25") wide by 600mm (23.6") high.

The hearth should be flat and comply with the Building Regulations viz. a minimum project of 420mm. (16 ½") from the face of the surround to the front edge of hearth. Any kerb on front edge must not be more than 25mm. (1") to allow the appliance door to open fully.

Boilers are despatched with the door and surround fitted.

Remove the door to protect the glass and surround before commencing installation.

Boiler Location

With the surround fixing frame screws in fully, position the appliance centrally and push the boiler back until the screws touch the surround. Ensure that the boiler sits level on the hearth in both directions so as to avoid the possibility of trapping air within the boiler.

Water connections can now be made to the heating and domestic hot water systems via the opening in the side of the chimneybreast.

Also make the flue connections as previously described.

Casing Assembly

Set the thermostat flap to an opening of 28mm, as shown in fig. 6.

Fit the back frame surround and loosely screw up at the fixing points.

Replace the door on its hinges and square the back frame surround with the door and firmly tighten screws.

Note: If the room heater is to be installed into recess, it is recommended that the casings be fitted before installation.

USER GUIDANCE

After completing the installation, the heating contractor should demonstrate to the user the operation of the room heater in particular the method of lighting, de-ashing and through plate cleaning.

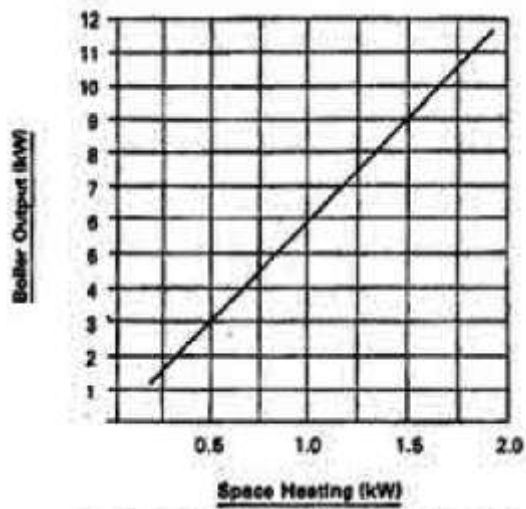
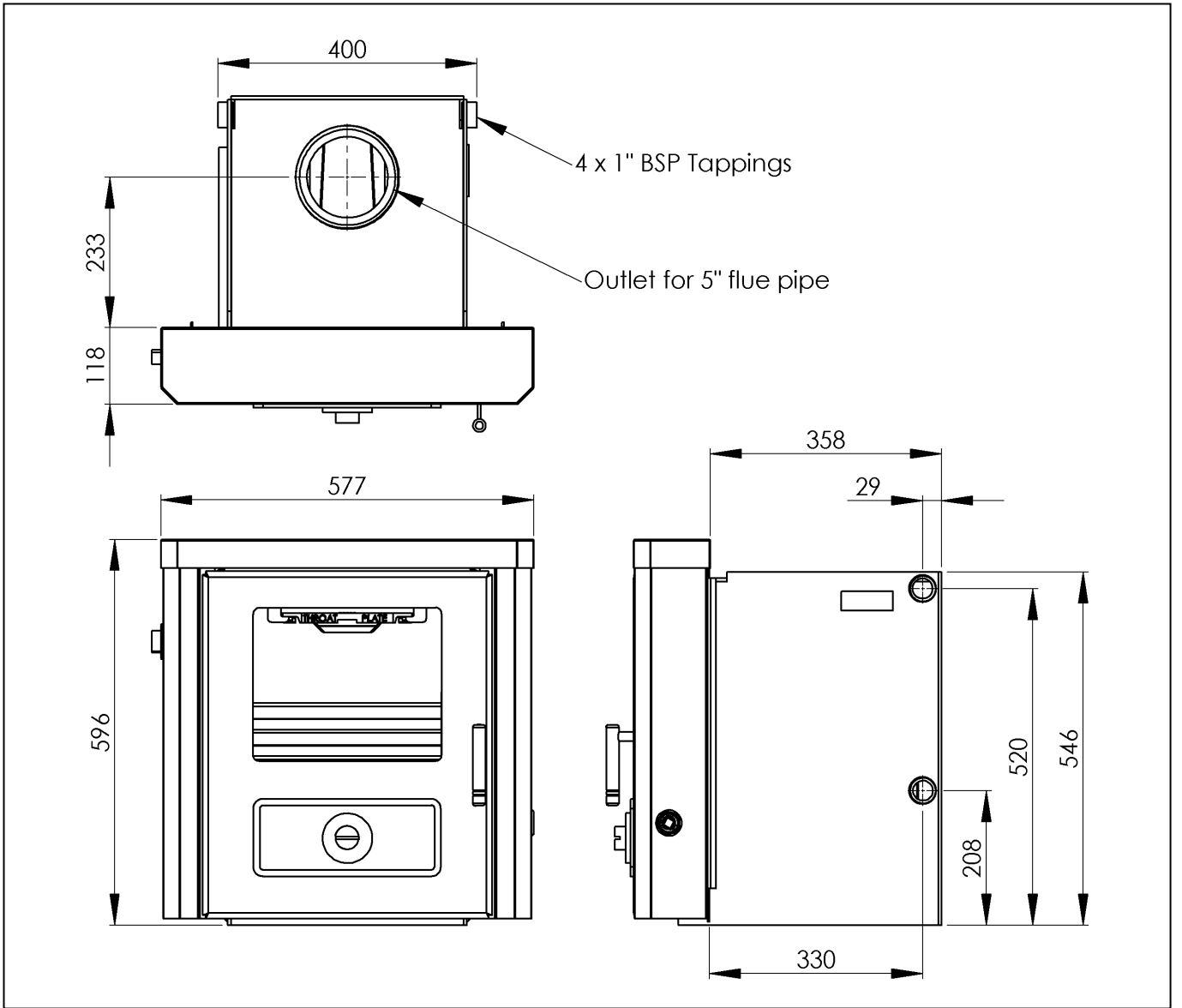

TRH MK4 ROOMHEATER



TR ENGINEERING LTD
Thorncliffe, Chapelton,
Sheffield, S35 2PH
Tel: (0114) 2572300
Fax: (0114) 2571419
www.trianco.co.uk

© TR Engineering Ltd. Copyright in this brochure and the drawings or illustrations contained within are vested in TR Engineering Ltd and neither the brochure or any part thereof may be reproduced without prior written consent.

TR Engineering's policy is one of continuous research and development. This may necessitate alterations to this specification. Instructions correct at time of going to print.

February 2011

Item No. 700655 Iss. 1 Rev. 0