



Fitting type: Undermount or Inset

Sink handing: Reversible

Finish style: Black metallic granite

- **Min. base unit (mm):** 450 (inset) 800 (undermount)
- **Packaged size L x W x D:** 696 x 576 x 262mm
- **Supplied boxed or sleeved:** Boxed
- **Boxed weight:** 13.31 kg
- **Sink only weight:** 9.50 kg

- Durable matt finish granite composite construction throughout
- Compact sink designed to complement smaller kitchens
- Softened square edges for a sharp but easy clean look
- Model can be undermounted or inset fitted
- Stainless steel wastes and pipework included

Included parts:



1 x AX1002 (m)
90mm (1.5") Orbit manual basket
strainer waste - long bolt



1 x AX1104 (m)
Rectangular overflow (55x30mm
horizontal)



1 x AX1008 (m)
1.0 Bowl pipework



1 x AX4049 (m)
Synchronist composite inset &
undermount instruction



1 x AX1032
Composite inset fixing clips x 6



1 x AX1153 M
6 x Undermount clip, 6 x 17mm long
x Ø10.64 soft thread tapex & 6 x
30mm domehead screw

Recommended accessories:



1 x AX2506
System Drainer / Trivet (roll up)



1 x AX1508
System Colander



1 x AX2024
System Bamboo Chopping Board

All accessories can be purchased directly from www.abode-shop.co.uk or phone 01226 283434

Materials & workmanship warranty summary:

- Sink materials & workmanship 10 years.
- Waste kits 1 year.
- Connecting pipework 1 year.

Care instructions summary:

- Clean the products regularly using soapy water and a non-abrasive cloth, regular cleaning will prevent the build-up of lime scale and dirt.
- Avoid contact with corrosive or abrasive substances.
- After cleaning rinse thoroughly with clean water then dry.
- For more detail see supplied booklet or www.abodedesigns.co.uk

Product dimensions and installation information: note:  symbol indicates position of acoustic pad on stainless products.



***Important, fabricator / installer notes for undermount & Flushmount sinks:**

The cut out size indicated is aligned with outside edge of the bowl top radius (similar to the example below).

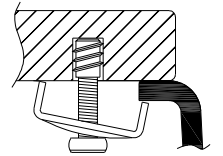

You should confirm with your client if the worksurface cutout is to be cut flush, inside or outside this suggested perimeter shape & size.

If you create the cutout smaller or larger than the indicated size then the fit of the accessories may be affected and should be physically checked.

General:

All details are provided in good faith but do not include the tolerances of the material or manufacturing process.

We request that a test cutout is made in scrap timber and checked against the actual sink to be installed before committing to cutting the final worksurface.

Abode can not accept liability for problems or costs incurred by failure to follow this request.

Note: the dimensions on ceramic fireclay products are subject to wider tolerances due to the nature of this natural material and the firing process.

CAD cutout files can be downloaded from www.abodedesigns.co.uk

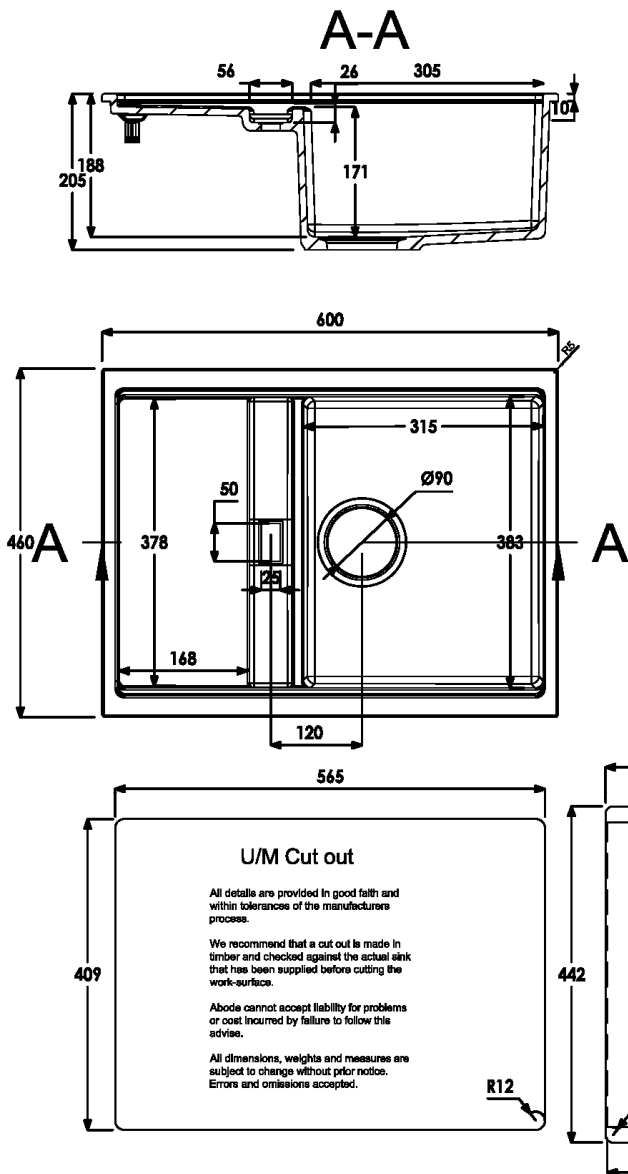

Additional notes: Repeated release of boiling hot water directly into coloured sinks can in extreme cases cause crazing and even cracking. Therefore we recommend great care is taken not to release the water directly on to the sink surface at full temperature.

Overall product size: 600 x 460 x 210, corner radius 5 mm

Taphole(s) detail: None

Wastehole(s) detail (mm): 90 / N/A / N/A

Min. base unit (mm) (refers to space required for bowl, tap and overflow only): fits 450 (inset) 800 (undermount) carcass

Min. Recessed fitting width (mm): required (bowl(s), tap and overflow:

***Worktop cut out size (mm):** 584 x 442, corner radius 12, for .DXF cut files please see our website

Min. & Max worktop depth or clip depth reach range (mm): 35 - 50

Fitting temple supplied?

Dishwasher under drainer? Distance from top of worktop to underside of the drainer 10 mm

Bowl details: (sizes in mm unless specified otherwise)

Bowl 1 (typically main bowl):

Bowl 1 size L x W x D (mm): 315 x 383 x 176

Bowl 1 construction: Moulded, 10.00 mm

Bowl 1 floor radius (mm): 10

Bowl 1 Wastehole diameter (mm): 90

Bowl 1 overflow: Rectangular horizontal

Bowl 1 texture: Matt textured

Bowl 1 apx. volume (litres): 18.80

Bowl 2 (typically 1/2 or 3/4 bowl):

Bowl 2 size L x W x D (mm): 383 x 56 x 21

Bowl 2 construction: Moulded, 10.00 mm

Bowl 2 floor radius (mm): 6

Bowl 2 Wastehole diameter (mm): N/A

Bowl 2 overflow: Rectangular flush

Bowl 2 texture: Matt textured

Bowl 2 apx. volume (litres): 0.30

Bowl 3:

Bowl 3 size L x W x D (mm): N/A x N/A x N/A

Bowl 3 construction: N/A, N/A mm

Bowl 3 floor radius (mm): N/A

Bowl 3 Wastehole diameter (mm): N/A

Bowl 3 overflow: N/A

Bowl 3 texture: N/A

Bowl 3 apx. volume (litres): N/A

