

Level Best Deflector Screen

Level Best Screens - Level Best Deflector Screen



Product Overview

Level Best is a fixed glass screen designed with a pivoting deflector panel. This type of solution does not span the entire distance of the shower area but it is long enough to provide water deflection.

Features

- + Bright silver chrome finish aluminium frame
- + 6mm toughened glass tested to EN12150
- + Screens tested EN 14428
- + 20mm compensator adjustment on wall fixing
- + Deflector Screen with Rising Butt Hinge
- + The panel rotates 250° and locks at 55° and 305° from the fixed panel
- + Stay clear coating on both sides



Benefits

- + Rising butt hinge for the deflector panel allowing an easy manipulation
- + The advantages of 6mm glass over 8mm or thicker glass are: lighter weight panel making it easier for the user to open – important feature for the care market – plus it puts less stress on the door hinges, which is important for long-term performance
- + Easy installation
- + Compatible with wet floors and vinyl flooring



Product Specification

- + Hinge attached to the fixed panel
- + Corner block to suit Vinyl flooring round corner
- + 1 fixed panel and 1 moving panel
- + Non handed
- + Screen height : 1900mm
- + Fixed panel widths are: 600(+0/-20)mm, 700(+0/-20)mm, 800(+0/-20)mm, 900(+0/-20)mm, 1000(+0/-20)mm
- + Deflector panel widths is: 350mm

Materials of construction:

- + Glass
- + Aluminium

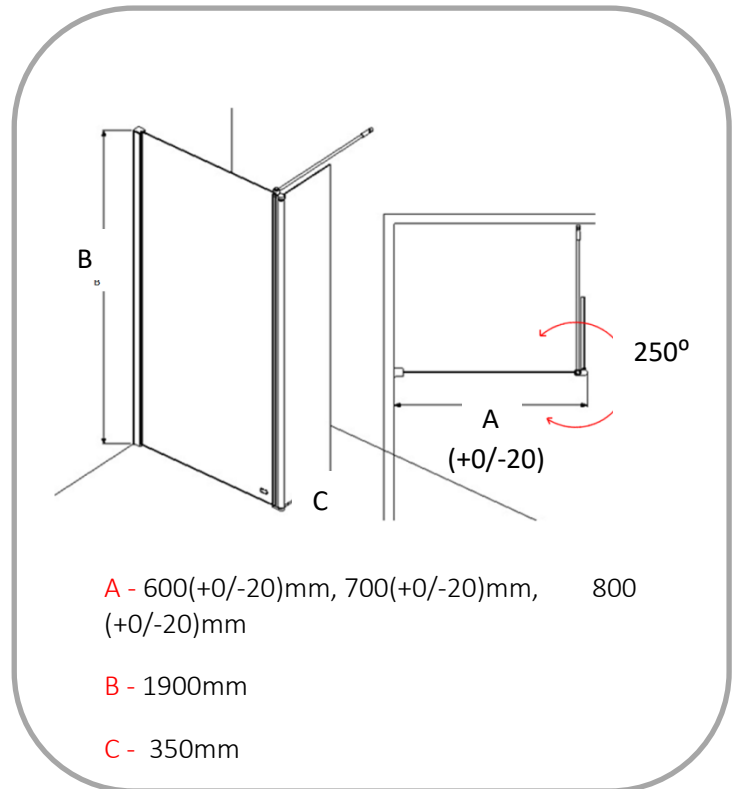

Code	Description
27019	Level Best Deflector Panel 1900x600x350mm
27020	Level Best Deflector Panel 1900x700x350mm
27021	Level Best Deflector Panel 1900x800x350mm
27022	Level Best Deflector Panel 1900x900x350mm
27028	Level Best Deflector Panel 1900x1000x350mm

www.akw-ltd.co.uk

AKW, Pointon Way, Hampton Lovett, Droitwich Spa, WR9 0LR

Order Line: 01905 823 299 | General Enquiries: 01905 823 298 | Fax: 01905 823 297 | E-Mail: sales@akw-ltd.co.uk