

**1800 Series Double Fold-Up Support Bar + Optional Toilet Roll Holder**

<b>Models</b> <input checked="" type="checkbox"/> 01810 ( <input checked="" type="checkbox"/> WH <input checked="" type="checkbox"/> BU ) <input type="checkbox"/> 01830 ( <input type="checkbox"/> WH <input type="checkbox"/> BU ) <input type="checkbox"/> 01820 ( <input type="checkbox"/> WH <input type="checkbox"/> BU ) <input type="checkbox"/> 01830 ( <input type="checkbox"/> SS )	<b>Code Compliance</b>
--	------------------------

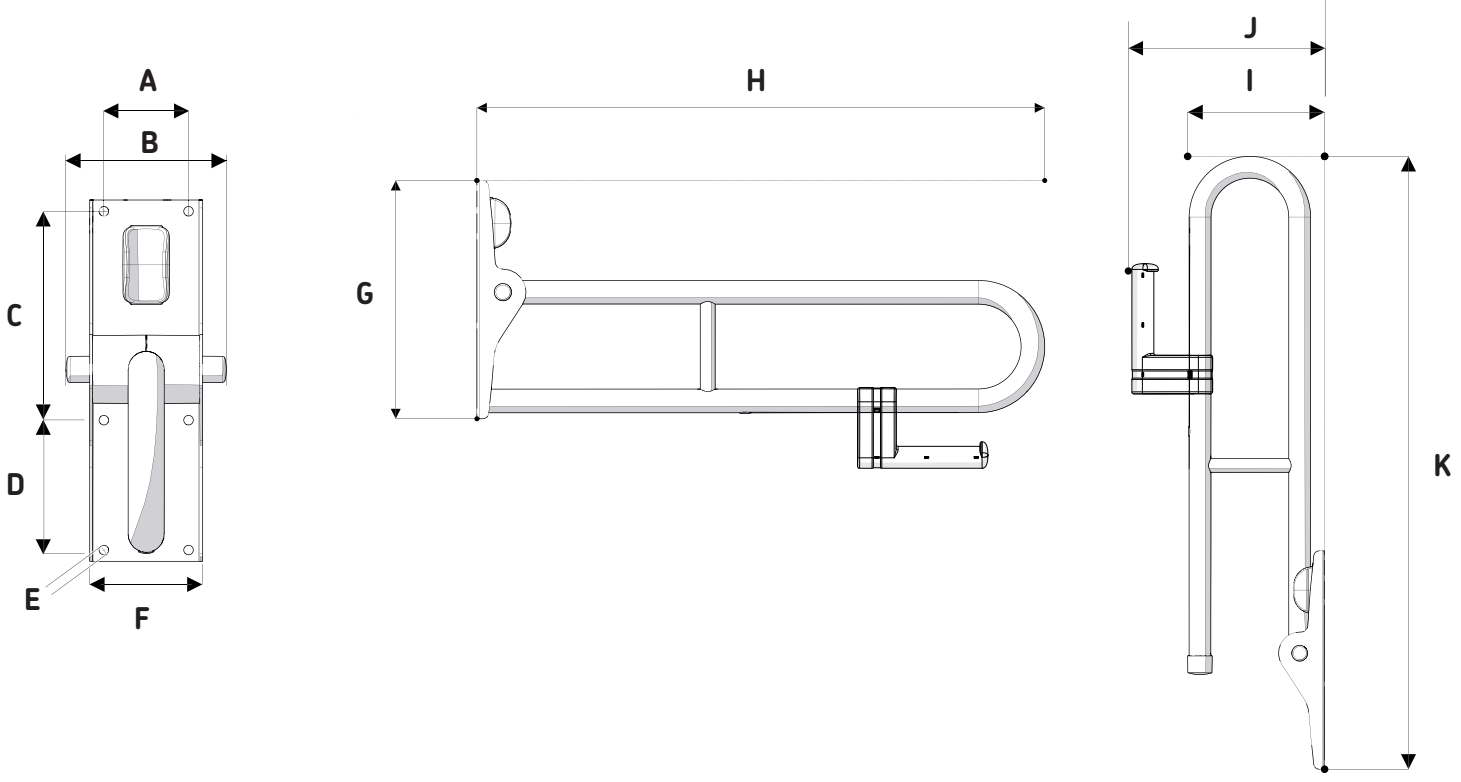

Fixing Plate Dimensions							Support Rail Dimensions				
A	B	C	D	E	F	G	H	I	J	K	
3"	5 1/2"	7 3/8"	4 1/2"	3/8" diam	4"	12 1/2"	30"	8"	11 1/2"	35 1/2"	
75mm	142mm	185mm	115mm	8.5mm diam	100mm	320mm	763mm	202mm	290mm	900mm	

<b>Technical Specifications</b> Composition: Shipped Weight: 10lbs Handing: Non -handed Weight capacity: 220kg/ 440lbs when properly fastened to blocking/concrete Colors: White or Blue Warranties: 10 years for residential use or 5 years for commercial use	<b>Features</b> <ul style="list-style-type: none"> <li>Folds neatly back to wall when not in use</li> <li>Optional fit toilet roll holder supplied</li> </ul>	<b>Recommended Accessories</b> <ul style="list-style-type: none"> <li><input type="checkbox"/> Heavy-Duty Grab Bar</li> <li><input type="checkbox"/></li> <li><input type="checkbox"/></li> </ul>
---	---	---