

Onyx Exclusif Shower Tray

INSTALLATION INSTRUCTIONS

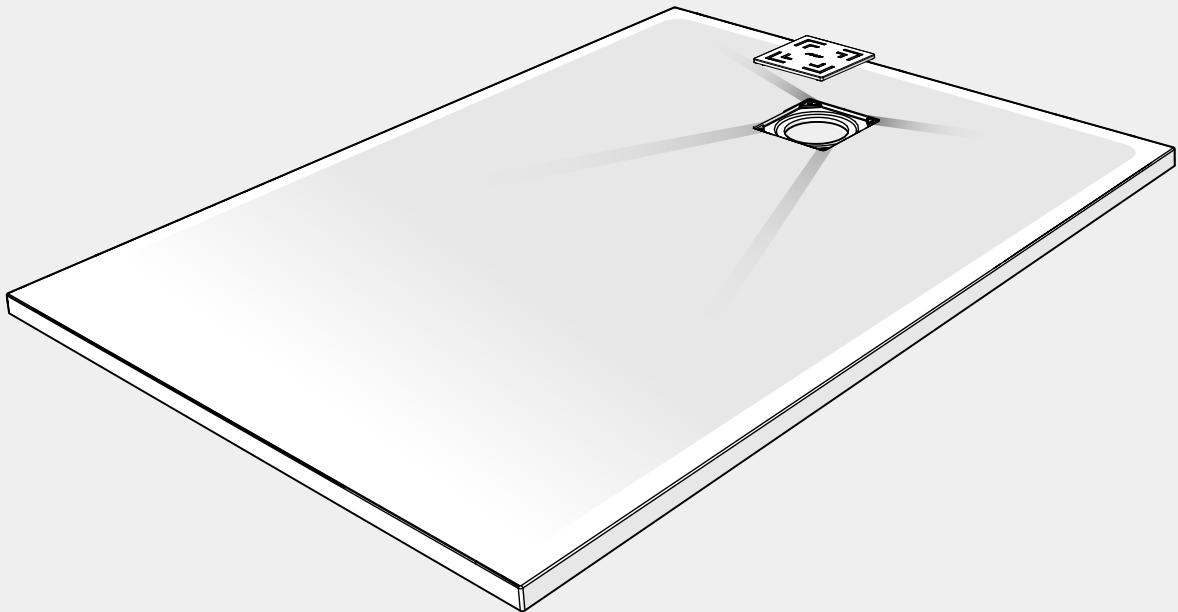

Please read all instructions before installation and leave this document with the end user for future reference as it contains important warranty information

Contents

CONTENTS

Important Information	3
Wooden Floor Installation	5
Solid Floor Installation	6
User Care & Warranty	7

Installation must be carried out in accordance with these instructions, and must be conducted by a qualified and competent installer.

By proceeding with installation, you are accepting that the product is in a suitable condition. Claims of faulty/damaged product once installation has begun are void.

The manufacturer is not responsible for any costs incurred through installation that is not in accordance with these instructions.

Caution:

- This product is heavy. Get someone to help lift and install it if necessary.
- Use the appropriate personal protective equipment when using power tools.
- Disconnect power tools from the electrical supply when you have finished with them.
- Make sure that any electrical cables do not cause a trip hazard.

Before you start work:

- Remove the packaging, taking care not to damage the product.
- Verify that all parts are present and in good condition.*
- Check for any buried cables or pipework before drilling into or breaching the floor.

While you work:

- Make sure that all surfaces are clean, dry, and free from dust and debris.
- Protect the surface of the shower tray and cover the waste to prevent anything from entering the waste trap.
- Follow the manufacturer's instructions when applying any degreasing agent or silicone sealant.
- Use the external packaging to protect the floor while you assemble the product.
- Use a spirit level throughout the installation.

After installation:

- Do not wet the shower enclosure for 24 hours to ensure that any silicone sealant is fully cured.
- Dispose of the packaging in accordance with local recycling authorities.

* Notify the retailer immediately if there are missing items or any faults with the product.

Important Information

Specification

- Tray height: 26 mm
- Slate finish
- SMC waste cover
- Concealed waste
- High water flow rate*
- Weight load: 200 kg
- Webbed back reinforcements
- Material: SMC (Sheet Moulding Compound)



* Flow rate depends on the waste.

Placement

Suitable for 'on floor' or 'in floor' installations. For wooden floor installation, use a suitable grab adhesive.

For solid floor installation, use a mix of 6:1 sand and cement to secure the tray down into position. It is recommended when removing solid floor material, to remove a minimum depth of double the thickness of the tray.

Ensure that the floor levels are tested before and after the installation, water test the flow from tray into waste for correct installation and drainage efficiency. It is important to ensure that the floor is level in all directions before putting the tray into place. If water puddles away from the waste, this is a clear indication that the levels are not correct. The water must drain towards the waste.

The sides of the tray **A** and **B** may well show level on testing, but if point **C** is low, then water will puddle in the area of point **C** and the only remedy is to level the floor and refit the tray. The tray has 'lands' on all four sides. Use a spirit level front to back and side to side - all 'lands' must be level (**ABC**) - the fall is moulded into the tray.

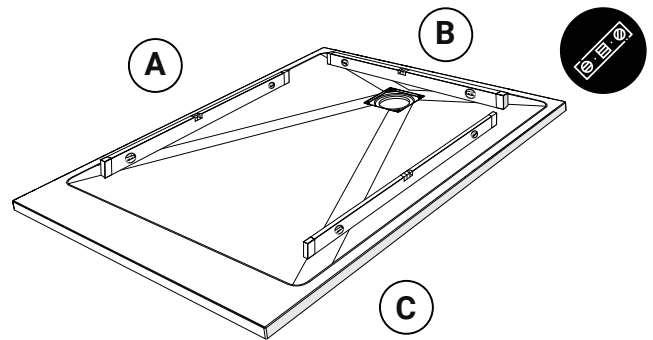

Trimmable Trays

Trimmable to within 150 mm of waste.

If trimming is absolutely necessary to avoid obstructions or tricky installations then Onyx trays can be trimmed down to within 150 mm of the waste cover area. The sides on the tray **X** and **Y** shown are shaded out to show the trimmable areas.

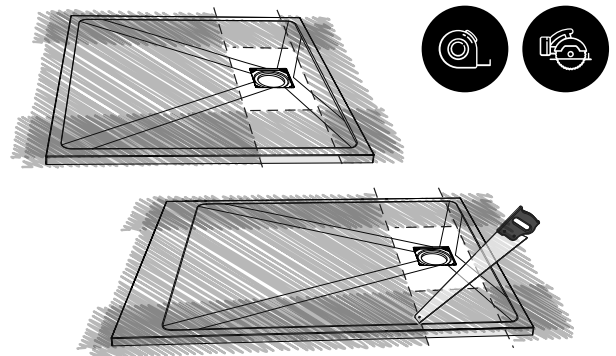

Wooden Floor Installation

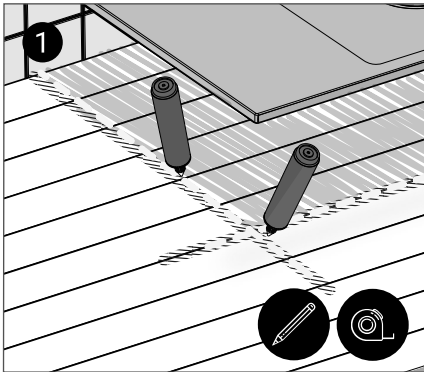

1 Position the tray over the desired location for the shower and outlet pipe. Mark around the edge of the shower tray.

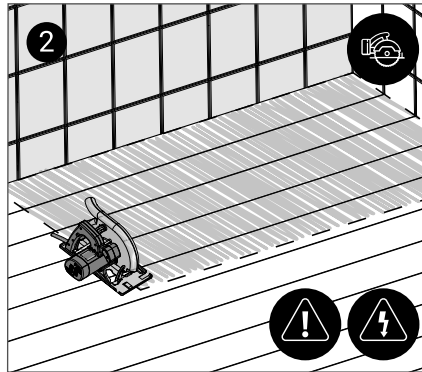

2 For 'in' floor installation, cut into the flooring, taking care not to cut through supporting joists or any plumbing or electrical wiring.

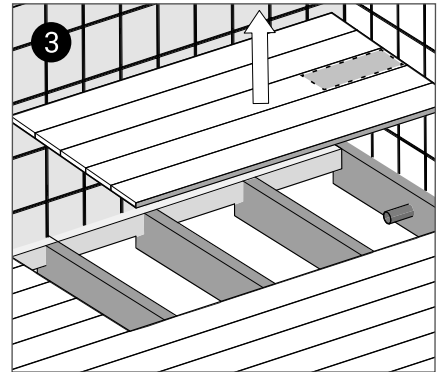

3 Carefully remove the floor boards and locate the waste outlet pipe. For 'on' floor installation, remove the floor boards around the waste area.

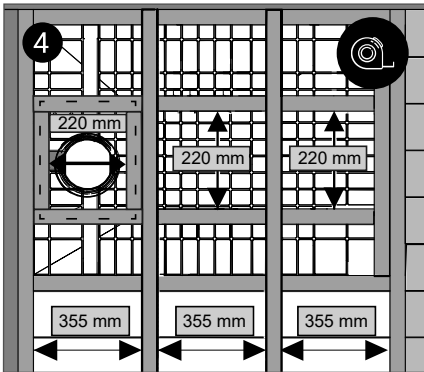

4 The waste area must be supported with additional noggins, 220 mm around the waste. Additional noggins or joists must be used on all tray edges and between joists centres at a minimum of 355 mm.

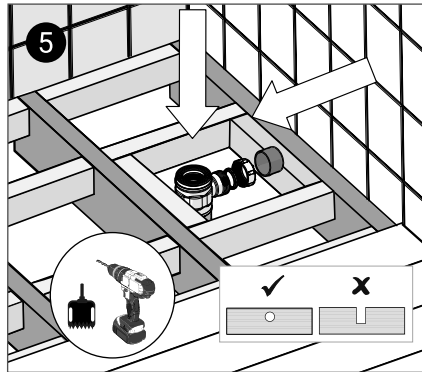

5 Install the waste drain trap and waste outlet pipe. Do not cut into the joists, always drill through when connecting to the waste outlet pipe.

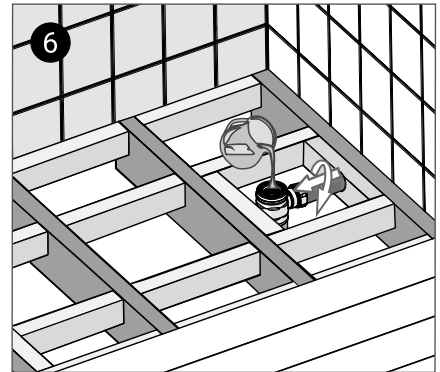

6 Water test the waste drain trap for flow and any leaks. Ensure that the rubber seal is in place. Remove any debris and ensure that there are no sharp edges or raised areas and check levels.

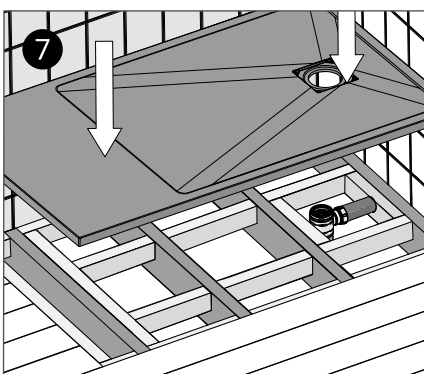

7 Apply grab adhesive to all the contact points between the tray, joists and noggins. Lower the tray over the waste position and firmly secure the tray into position and check all 4 sides are level again.

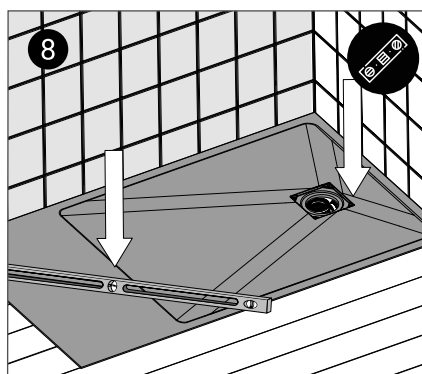

8 Attach the waste trap to the tray with the waste clamping ring, see separate waste instructions. Apply a waterproof membrane to the whole of the showering area, see manufacturers instructions.

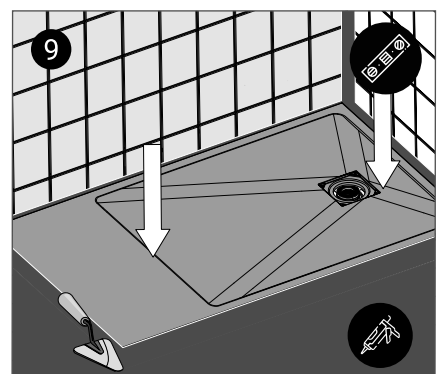

9 Safety flooring or tiles should finish flush up to the edges of the tray and sealed with sealant. Protect the waste trap from debris during installation.

Solid Floor Installation

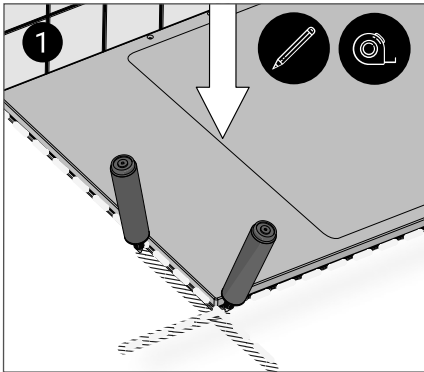

1 Position the tray over the desired location for the shower and outlet pipe. Mark around the edge of the shower tray and the waste area.

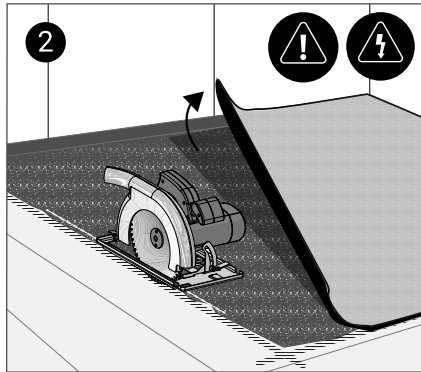

2 For 'in' floor installation, cut into the flooring, taking care not to cut through any supporting material, plumbing or electrical wiring.

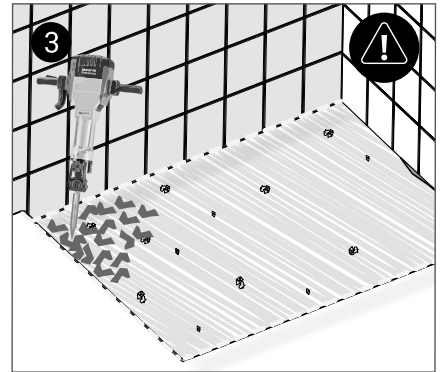

3 Carefully remove the flooring to suit the finished height of the tray and final floor covering. For 'on' floor installation, remove the material around the waste area.

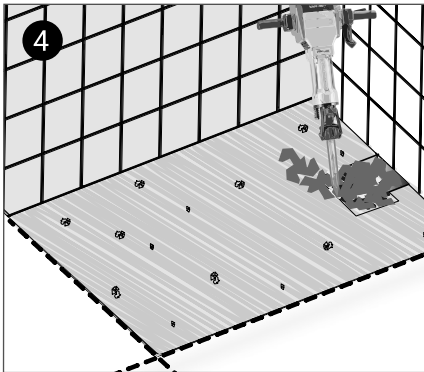

4 For 'in' floor or 'on' floor installation remove the floor material for the waste area and a channel for the outlet pipe.

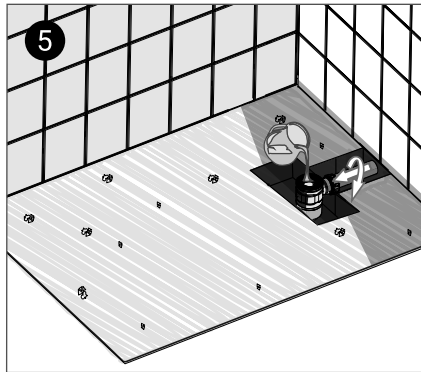

5 Install the waste drain trap and waste outlet pipe. Water test the waste for flow and for any leaks. Ensure that the rubber seal is in place on top of the trap. Check the waste drain position with the tray.

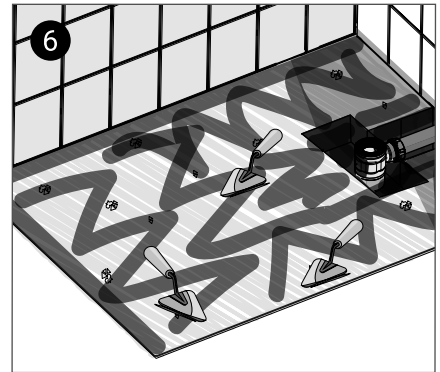

6 Remove any debris and ensure that there are no sharp edges or raised areas that will affect the tray height. Add 6:1 cement mix to the full tray area and correct height including all supporting edges.

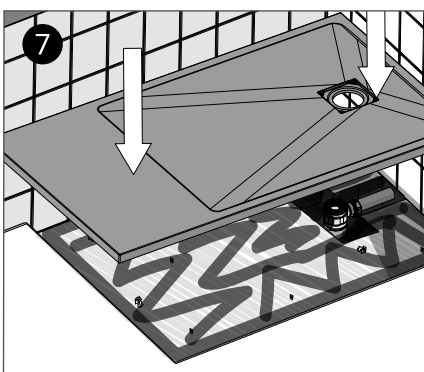

7 Lower the tray into position and check the height compared to the finished floor height. Firmly secure the tray into position and check all 4 sides are level again.

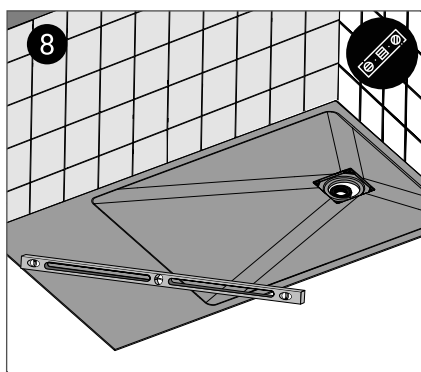

8 Attach the waste trap to the tray with the waste clamping ring, see separate waste instructions. Apply a waterproof membrane to the whole of the showering area, see manufacturers instructions.

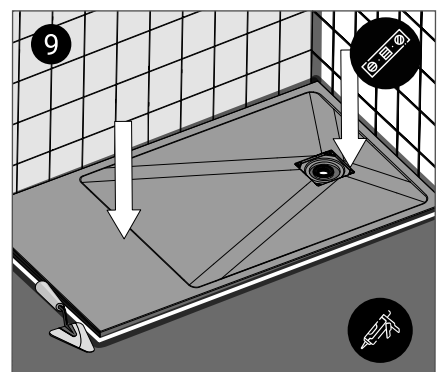

9 Safety flooring or tiles should finish flush up to the edges of the tray and sealed with sealant. Protect the waste trap and cover from debris during installation.

After Care

Provided that the shower tray has been correctly installed, difficulties should not be encountered. If any maintenance is required, it must be carried out by a competent installer. It is advised that this product is cleaned regularly as part of a routine maintenance regime. Always rinse the shower tray down using warm water after every wash to remove any insoluble products. If you use hair dye, immediately rinse the shower tray with soap and water. For routine cleaning, use hot soapy water or a mild detergent and a soft cloth to wash and rinse the showering area. Never use abrasive cloths or any aggressive cleaning materials to clean the showering area. Do not use industrial cleaners that have abrasive or harsh chemical properties as this could affect the surface finish. The surface of this shower tray should never directly come into contact with strong industrial acids or alkalis, organic solvents, caustic soda, lacquers or nail polishes, bleaches or any dry powder cleaning agents. Do not use paint strippers or stain removers to remove any stubborn staining. If more thorough cleaning is needed using domestic cleaning products always test on a small area first.

Warranty

Lifetime warranty applies only to manufacturing or material defects. AKW products should be installed by a competent installer or trades persons using appropriate fixings suitable for the condition of the surfaces on which the product is to be attached.

The selection of any specific fixings must be made by the installer based upon the requirements for each individual installation.

If you do not install these products in accordance with these supplied instructions, or if you carry out any unauthorised modifications to this product, you will affect product safety and invalidate this warranty. Warranty starts from the date of installation. Always keep proof of purchase.

Warranty does not cover

- Normal wear and tear, inappropriate use or accidental damage.
- Damage or defects that result from incorrect installation, improper use, breakages or lack of maintenance including the build up of grime, dirt, lime-scale and water-borne debris.
- Damage resulting from inappropriate cleaning, staining or water ingress.
- Damage or defects that result from repairs or modifications undertaken by persons who are not installers or service engineers.
- Damage caused by impact.

What to do if something goes wrong?

In the event that you should encounter a problem with this product, please contact your local installer and if this does not resolve the issue, then contact AKW Technical Enquiries who will provide further advice and, if necessary, arrange for a maintenance engineer to visit and report any issues.

As part of our quality and training program, calls may be monitored or recorded.

None of the foregoing affects your statutory rights.

Contact Us

AKW
Life Made Better

Orders & Quotes

01905 823 299
orders@akw-ltd.co.uk

General Enquiries

01905 823 298
sales@akw-ltd.co.uk

Technical Enquiries

01905 560 219
tech@akw-ltd.co.uk

Kitchen Enquiries

01905 823 262
kitchens@akw-ltd.co.uk

Fax

01905 823 297

AKW

Pointon Way, Hampton Lovett
Droitwich Spa, WR9 0LR

www.akw-ltd.co.uk
orders.akw-ltd.co.uk

Follow us on Social:



Warranty

Warranty applies only to manufacturing or material defects, conditional on the one-time correct installation of the product. It does not apply to:

- Inappropriate use or accidental damage.
- Damage or defects that result from incorrect installation.
- Lack of maintenance including the build up of grime or damage resulting from inappropriate cleaning.
- Damage or defects that result from repairs or modifications undertaken by unauthorised persons.
- General wear and tear through usage and does not apply to surface finishes.

Warranty period starts from the date of installation. See the T&Cs on our website for further information.

Select 1 of 2 ways to activate your warranty



1. Scan using your Smart Device



2. Visit Online

akw-ltd.co.uk/warranty-information

What to do if something goes wrong?

In the event that you encounter a problem with this product, follow the trouble shooting guide if applicable, then contact your local installer. If the issue is still unresolved, contact AKW Technical Enquiries who will provide further advice and arrange for a maintenance engineer to visit if necessary. None of the foregoing affects your statutory rights.