

Technical Datasheet

Product Code: 237099-N

Product Description: Arley Stirling 2 Urinal In A Box With Brackets



Specification

Product Guarantee:	25 Years
Barcode:	237099-N
Packaged Weight (kg):	11.9 kg
Packaged Length (Metre):	0.58
Packaged Width (Metre):	0.365
Packaged Height (Metre):	0.36
Material:	Ceramic



Key Features

- Sleek lines add an element of style to your bathroom
- Manufactured from high quality white ceramic
- Designed to be used with concealed or exposed pipework
- Complete with brackets for a quick wall installation
- Matching items are available to purchase from the Arley range

Technical Drawing

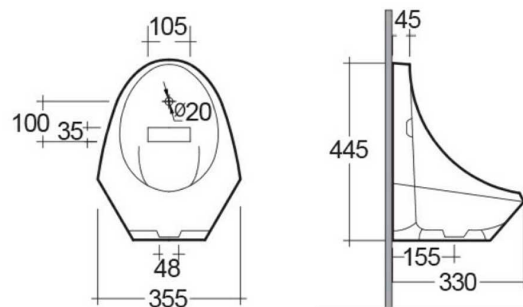

Dimensions: All measurements are in millimetres and are subject to normal manufacturing variations.

Due to a continuing development programme to improve design and performance, we reserve all rights to vary specifications without prior notice. Please note, all accessories are for photographic purposes only.