

# Technical Datasheet

Product Code: 237099.WK500



Product Description: Arley Warwick 500mm Urinal In A Box Comes With Bracket & Waste

## Specification

Barcode:	5060394690374
Packaged Weight (kg):	13.5 kg
Packaged Length (Metre):	1.1
Packaged Width (Metre):	0.78
Packaged Height (Metre):	0.75
Material:	Ceramic
Made In the UK:	Yes



## Key Features

- Modern curvaceous design with smooth & stylish lines
- Manufactured from quality white ceramic
- Ideal for domestic & commercial use
- Matching sanitaryware are also available in the Warwick range
- Complete with white doomed waste & brackets
- Also available in 400mm

## Technical Drawing

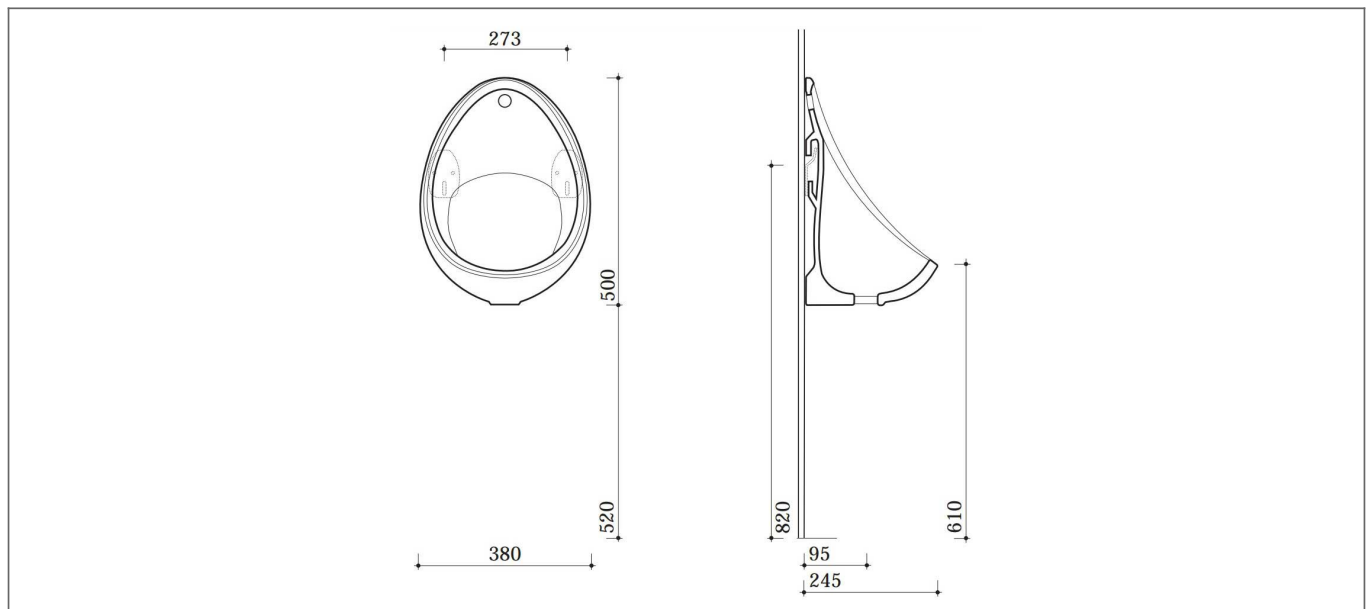

Dimensions: All measurements are in millimetres and are subject to normal manufacturing variations.

Due to a continuing development programme to improve design and performance, we reserve all rights to vary specifications without prior notice. Please note, all accessories are for photographic purposes only.