

Technical Datasheet

Product Code: 989100186632WRAS



Product Description: Arley 860 x 500mm 1.0 Bowl & Drainer Kitchen Sink & Tap Pack

Specification

Product Guarantee:	25 Years
Projection (mm):	500
Material:	Stainless Steel
Style:	Modern
Shape:	Rectangular
Number Of Tap Holes:	1



Key Features

- Sleek lines adds an element of style to your bathroom
- Manufactured from high quality stainless steel
- Features 1 tap hole suitable for mono basin mixer use
- Features lever control for a flawless level flow
- Comes complete with lever tap, waste & fixing clips
- Alternatively available in 1000x500mm

Technical Drawing

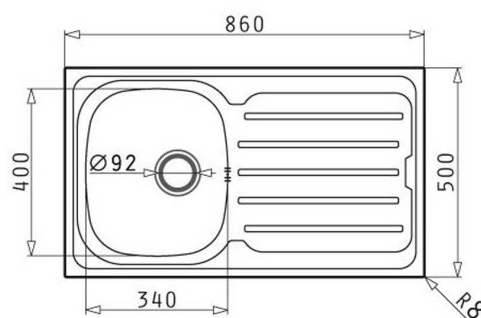

Dimensions: All measurements are in millimetres and are subject to normal manufacturing variations.

Due to a continuing development programme to improve design and performance, we reserve all rights to vary specifications without prior notice. Please note, all accessories are for photographic purposes only.