

# Technical Datasheet

Product Code: 23701RHDEL-NC



Product Description: Arley Deluxe Raised Height Bog In A Box Comes With Soft Close Seat

## Specification

Product Guarantee:	1 Year
Packaged Weight (kg):	40 kg
Material:	Ceramic
Projection:	615
Style:	Modern
Flush Type:	Push Button
Cistern Flush:	Dual Flush
Approvals:	WRAS Approved
Includes Seat:	Yes
Seat Type:	Soft Close



## Key Features

- Modern curvaceous design with smooth & stylish lines
- Manufactured from high quality white ceramic
- Ideal design for people with reduced mobility
- Features water saving dual flush 3/6 litre cistern
- Soft close seat for minimal noise & added safety measure
- Cistern is complete with push button & all internal fittings

## Technical Drawing

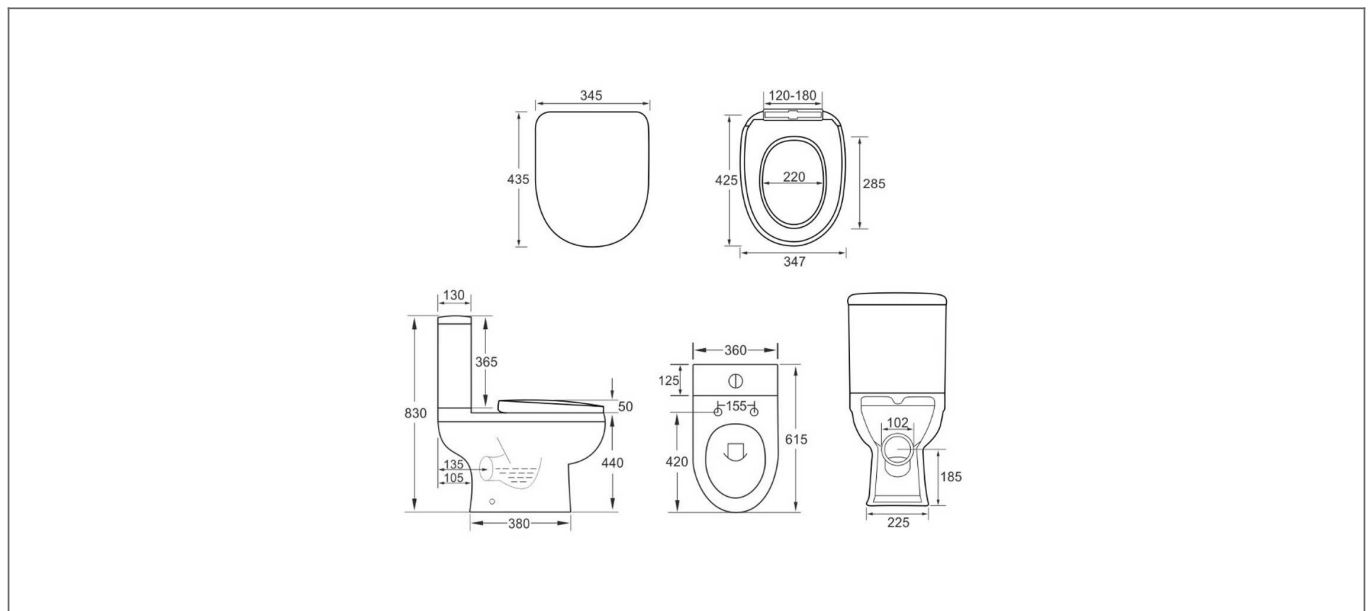

Dimensions: All measurements are in millimetres and are subject to normal manufacturing variations.

Due to a continuing development programme to improve design and performance, we reserve all rights to vary specifications without prior notice. Please note, all accessories are for photographic purposes only.