

# VAX HNK C

## VALUE Tap Range X Head High Neck Pillar Taps Chrome



### Features:

- Metal handles
- Metal back nuts for added durability
- Chrome plated to BS EN 248

### Product Certifications:



WRAS Certificate No: 240103001  
WRAS Expiry Date: 31/01/2029



For more products, visit our website:  
<http://www.bristan.com>



### Specification

Product Type:	Taps
Main Construction Material:	Brass
Mount Type:	Deck
Handle Type:	Crosshead Handles
Connection Inlet:	1/2" BSP
Connection Outlet:	N/A
Number of Tap Holes:	2
Valve/Cartridge Type:	1/2" Standard Valve
Plumbing System Requirements:	Suitable for all plumbing systems
Minimum Dynamic Pressure (bar):	0.2 bar
Maximum Dynamic Pressure (bar):	5 bar
Maximum Hot Water Temperature °C:	65°C
Maximum Static Pressure (bar):	10 bar
Isolation Included:	No

### Dimensions (measurements in mm)

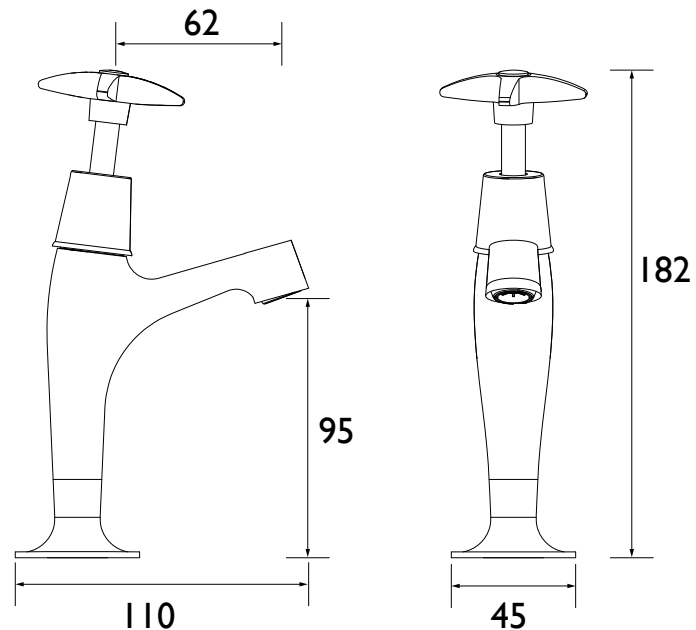

### Flow Rates (l/min)

System Pressure (bar)	0.2	0.5	1	2	3	5
VAX HNK C (Cold)	13.9	21.9	31	43.8	53.7	69.3
VAX HNK C (Hot)	13.9	21.9	31	43.8	53.7	69.3

## TECHNICAL DATA SHEET



# BRISTAN

D11.1