

# DUL3 THBSM C

## DU LEVER Tap Range Design Utility Lever TMV2 Thermostatic Bath Shower Mixer Chrome



### Specification

<b>Product Type:</b>	Bathroom Taps
<b>Main Construction Material:</b>	Brass
<b>Mount Type:</b>	Deck
<b>Handle Type:</b>	Lever
<b>Connection Inlet:</b>	3/4" BSP
<b>Connection Outlet:</b>	Flow Straightener
<b>Number of Tap Holes:</b>	2
<b>Valve/Cartridge Type:</b>	1/2" Ceramic Disc Valve - 1/4 turn
<b>Plumbing System Requirements:</b>	Suitable for Nominally Balanced Supply Pressures Only
<b>Minimum Dynamic Pressure (bar):</b>	0.5 bar
<b>Maximum Dynamic Pressure (bar):</b>	5 bar
<b>Maximum Hot Water Temperature °C:</b>	65°C
<b>Maximum Static Pressure (bar):</b>	10 bar
<b>Flow Type:</b>	Dual
<b>Isolation Included:</b>	No

### Features:

- Maintain a consistent, safe water temperature with the TMV2 certified thermostatic valve
- Override temperature limits when needed with the convenient safety override feature
- Easily fit, maintain or replace with the WMNT 10 Fast Fixing Kit
- Control your experience with dual controls for separate flow and temperature adjustment
- Built to last, backed by a lifetime parts and 1-year labour guarantee

### Product Certifications:



WRAS Certificate No: 2309907  
WRAS Expiry Date: 30/09/2028



TMV2 Certificate No: NSF-2310966  
TMV2 Expiry Date: 15/03/2028

### Dimensions (measurements in mm)

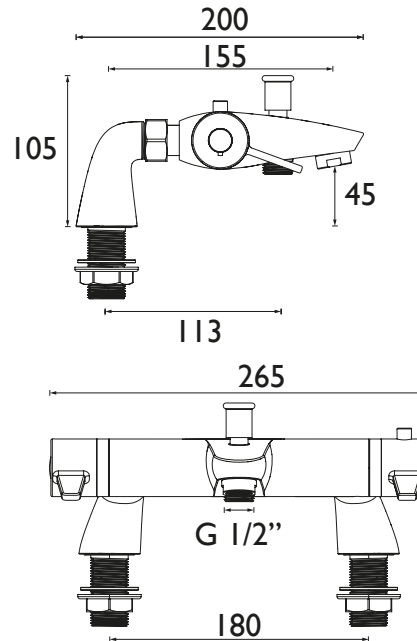

### Flow Rates (l/min)

System Pressure (bar)	0.5	1	2	3	5
Through Bath Filler (mixed)	8.1	12.2	17.7	21.8	28.5

## TECHNICAL DATA SHEET



# BRISTAN

D13