

AFTERCARE INSTRUCTIONS

Your fitting has a high quality finish and should be treated with care to preserve the visible surfaces.

All surface finishes will wear if not cleaned correctly, the only safe way to clean your mixer is to wipe with a soft damp cloth. Stains can be removed using washing up liquid. All bath cleaning powders and liquids will damage the surface of your fitting, even the non-scratch cleaners. **NOTE: Never use abrasive detergents or disinfectants or those containing alcohol, hydrochloric acid or phosphoric acid.**

GUARANTEE

All products are manufactured to the highest standards and a 5 year guarantee covers any defect in manufacture.

NOTE: The 5-year guarantee on the cartridge is invalidated if damaged by any waterborne debris.

All products must have access for servicing or replacement during the life of the product.

In the interests of continuous product development we reserve the right to alter specification as necessary

PRODUCT CODE:

PLEASE ENTER YOUR PRODUCT CODE ABOVE IN THE BOX PROVIDED, WHICH WILL BE REQUIRED FOR ANY FUTURE CORRESPONDENCE REGARDING THIS PRODUCT

PRODUCT IDENTIFICATION CODE LASER ETCHED ON PRODUCT
Installer please fill in code here _____.(Where applicable)

TELEPHONE HELPLINE! +44 (0)844 701 6273

Bristan Group Limited
Birch Coppice Business Park
Dordon
Tamworth
Staffordshire
B78 1SG
UK
A Masco Company
Website: www.bristan.com
Telephone: +44 (0) 844 701 6274
Facsimile: +44 (0) 844 701 6275
Email: enquire@bristan.com

BRISTAN

Qube Basin And Bidet Mixer

Fitting Instructions & Contents List

Please keep these instructions for future reference and request of replacement part

WATER PRESSURE

This mixer is suitable for use at all supply pressures. However for optimum use both the hot and cold supplies should be reasonably balanced.

If the fitting is installed at low pressure (tank fed), then the minimum distance from the highest installed position of the shower head to the underside of the cold tank should be 2 metres to ensure adequate shower performance.

This mixer should be installed in compliance with the Water Regulations. Where the supplies are unbalanced, i.e. hot water from cylinder tank/cold from the mains, approved check valves must be fitted in the supply pipes. For further details contact your Local Water Authority.

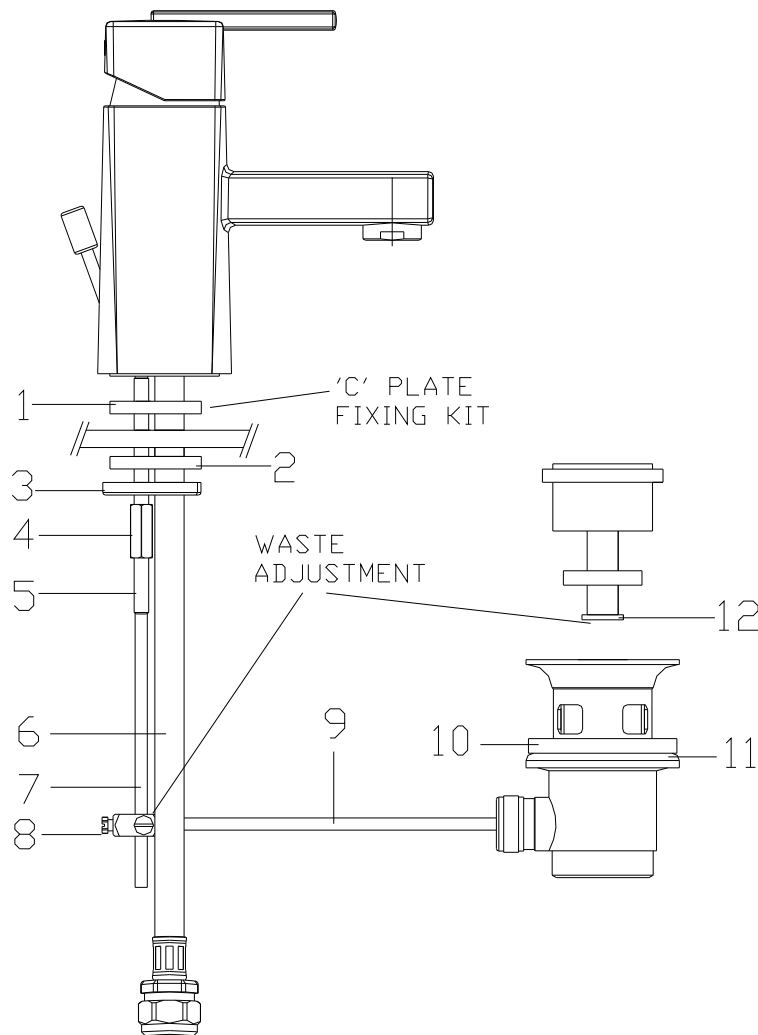

INSTALLATION

1. Identify all components and check for completeness, particularly before arranging fitting.
2. Fit the mixer body to the basin/bidet using the 'C' plate fixing kit. The full rubber washer (1) goes between the fitting and the basin/bidet, and the 'C' shaped rubber (2) and metal washers (3) on the underside of the basin/bidet, to be secured by the nut (4) and the threaded rod (5).
3. Fit the flexible tail pipes (6) to the inside of the fitting connect the hot and cold supplies. DO NOT OVERTIGHTEN (BY HAND ONLY).
4. Fit the pop-up waste, with washer (10) above and the shaped washer (11) below the basin/bidet. It is recommended that a silicon sealant be applied to both sealing faces of washers (10 & 11). The plug height can be set by, adjusting the waste rod (9) and operating rod (7) connecting bracket (8), and the screw (12) in the base of the plug.
5. Fully open the mixer in the mid position, letting them run for a few minutes and check all joints and connections for leaks.
6. See over the page for aftercare instructions.

N.B. Please write the name and product code of your fitting in the spaces provided overleaf. This will ensure a speedier service if you should need to phone the help line.

MAINTENANCE

If the fitting begins to drip

1. Isolate water supplies.
2. Prise out handle cap, loosen grub screw and lift off the handle.
3. Unscrew shroud and brass retaining plate and lift out the cartridge complete with seal.
4. Clean or replace cartridge, clean and grease seal and refit.

NOTE: That there are locating pins on the bottom of the cartridge that fit in Holes inside the tap, to ensure it is fitted the right way around.

5. Replace valve, collar, shroud and handle then turn on the water supply.
6. Contact our helpline if problem persists.

PLEASE NOTE:

In the unlikely event you find a part missing, please contact our Customer Service helpline on **0844 701 6273** for immediate dispatch of part