

## Bib or Globe Taps

## Fitting Instructions & Contents List

PRODUCT CODE: \_\_\_\_\_

**TELEPHONE HELPLINE: 0844 701 6273**

Bristan Group Limited  
Birch Coppice Business Park  
Dordon  
Tamworth  
Staffordshire  
B78 1SG  
UK

A Masco Company

Website: [www.bristan.com](http://www.bristan.com)  
Telephone: 0844 701 6274  
Facsimile: 0844 701 6275

Before starting any installation project please consider:

Prior to drilling into walls, check there are no hidden electrical wires, cables or water supply pipes with the aid of an electronic detector. If you use power tools do not forget:



- Wear eye protection
- Unplug equipment after use

**Please keep these instructions for future reference**

## WATER PRESSURE

This fitting is suitable for use at all supply pressures.

**Operating Pressures: Min 0.2 bar, Max 7.0 bar.**

If the fitting is installed at low pressure (tank fed), then the minimum distance from the highest installed position of the water outlet to the underside of the cold tank should be 2 metres to ensure adequate shower performance.

This fitting should be installed in compliance with the Water Regulations.

For further details contact your Local Water Authority.

### **IMPORTANT - PLEASE READ**

**This fitting needs to be installed in accordance with the following Installation Requirements and Notes (IRN) to ensure they meet the requirements of the Water Supply (Water Fittings) Regulations 1999 and the Scottish Byelaws 2004.**

#### **IRN R001**

See text of entry for Installation Requirements or Notes.

#### **IRN R040**

The fitting shall be installed so that its outlet discharges above the spill-over level of any fixed appliance as indicated below:-

**For backflow protection in domestic or installations up to, and including, Fluid Category 3.**

<b>1.</b> Size of tap or combination fitting.	<b>2.</b> Vertical distance of outlet above spill-over level.
1. Not exceeding 1/2in	20mm
2. Exceeding 1/2in but not exceeding 3/4in	25mm
3. Exceeding 3/4in	70mm

If the fitting cannot be installed as indicated in the table it shall be installed:

- a) with an approved double check valve assembly or some other no less effective backflow prevention device immediately upstream of the inlet; or
- b) so that it draws water by gravity only from a cistern, or cylinder having a permanently open vent pipe, and the distributing pipe supplies no other fittings (other than a draining tap) at a lower level.

**For backflow protection in premises or installations up to, and including Fluid Category 5.**

The vertical distance of the outlet above the spill-over level shall be not less than 20mm or twice the diameter of the inlet pipe to the fitting, whichever is the greater. If the fitting cannot be installed as indicated it shall be installed with a backflow prevention arrangement suitable for the Fluid Category.

Compensation for loss of use of the product or consequential loss of any kind. In the interests of continuous product improvement, Bristan reserves the right to alter product specifications without notice.

The Bristan Product Guarantee does not affect your statutory rights as a consumer.

#### Need Help?

If your product does not function correctly when you first use it, contact your plumber and make sure that it has been installed and commissioned in line with the instructions in this guide. If this doesn't solve the problem, then please visit [www.bristan.com/bristancare](http://www.bristan.com/bristancare) for some helpful hints and tips, or contact Bristan Care Customer Service on 0844 701 6273 where our expert team of advisors will be able to offer you, or your plumber, help and advice.

#### Problems During the Guarantee Period

In the unlikely event that you encounter any problems with the product during the guarantee period, contact Bristan Care Customer Service on 0844 701 6273 with your proof of purchase or unique guarantee registration number, and we will work to resolve the problem quickly.

#### Extended Guarantees

If your product is out of its guarantee period, or you would like to extend the guarantee, then please visit [www.bristan.com/customerservice](http://www.bristan.com/customerservice) for extended guarantee options.

#### Bristan Care Customer Support

Bristan customers also benefit from the support of Bristan Care, our comprehensive customer support package which offers:

Technical support hotline (Tel: 0844 701 6273) with access to fully trained advisors who can offer installation advice, talk you through quick maintenance checks, or recommend the best course of action to fix any problems with a product

Expert advice Find easy to follow 'how to' video guides and technical FAQs online at [www.bristan.com](http://www.bristan.com). Our guides take you step-by-step through many product installations and you can find plenty of easy guides to quick product fixes and servicing.

Spare parts We hold thousands of spares and we keep them for discontinued products for over seven years. Spares can easily be ordered online at [www.bristan.com](http://www.bristan.com) and are dispatched the same day.

Expert plumbing engineers If we can't solve the problem over the phone or with a spare part, then we'll send out one of our Bristan Care engineers to take a look. Bristan Care engineers provide free support for products that are within guarantee, but are also available to service products that are out of guarantee for a small charge. For details, please call customer services on 0844 701 6273.

## GUARANTEE

At Bristan, we want to make things as easy as possible for our customers.

That's why we design products that are easy to fit and use, and that are quality tested to make sure they won't let you down. It's also why we offer solid guarantees on all products, effective from the date of purchase, to give you peace of mind.

All Bristan taps and mixers are covered by a 5 year guarantee. This also includes 1 year labour cover\* which means that, in the unlikely event that you should encounter a problem in the first year after purchase, we'll send one of our expert engineers to fix it.

\*Labour is provided by an approved Bristan Care engineer or appointed representative. The guarantee only applies to products with a manufacturing fault. There will be a call out charge for any incidents where no fault has been found with the product, or if the issue is due to poor installation or maintenance.

### Register Now and Extend Your Cover

Register your tap/mixer with us now and we'll extend your labour cover to 2 years – FREE!

You can register quickly and easily online at [www.bristan.com/register](http://www.bristan.com/register). Alternatively, please fill in the details on the enclosed registration card and post it back to us.

### Guarantee Terms and Conditions

This guarantee is in addition to your statutory and other legal rights and is subject to the following conditions:

The product was purchased within the United Kingdom or Republic of Ireland.

The product is used in domestic applications only. For commercial or non-domestic applications such as leisure centres, sports clubs, hotels, premises operating as a business, the guarantee period is reduced to 1 year.

The guarantee applies solely to the original purchaser with proof of purchase.

The installation must allow ready access to all products for the purpose of inspection, maintenance or replacement.

Repair under this guarantee does not extend the original expiry date. The guarantee on any replacement parts or product ends at the original expiry date.

Any part found to be defective during the guarantee period will be replaced without charge, providing that the product has been installed in accordance with the instructions given in this guide and used as the manufacturer intended.

### The Guarantee Does Not Cover:

Damage or defects caused by

- general wear and tear (including special non-chrome finishes; components such as filters, seals, 'O' rings and washers)
- incorrect installation
- repair using non-Bristan parts
- accidental or wilful misuse
- corrosion and the use of inappropriate cleaning products.
- system debris including the build up of limescale (which can be controlled through regular servicing and maintenance)

## INSTALLATION

1. Identify all components and check for completeness, particularly before arranging fitting.
2. Using a suitable thread sealant install the taps into the connectors (not provided) Globe taps are supplied with a threaded tube (1) and, if used this needs to be Sealed into the tap body prior to connecting to pipework. The backnut (2) can be Used to hold the Globe tap with the threaded tube in the wall.
3. Turn on the water supplies. Open both taps letting the water flow for a few Minutes to flush the system.
4. Check all joints and connections for leaks.
5. See over the page for aftercare instructions.

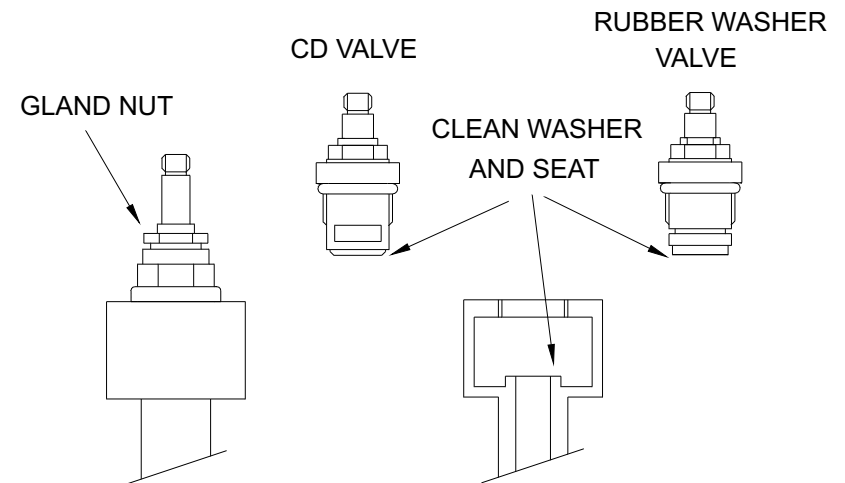
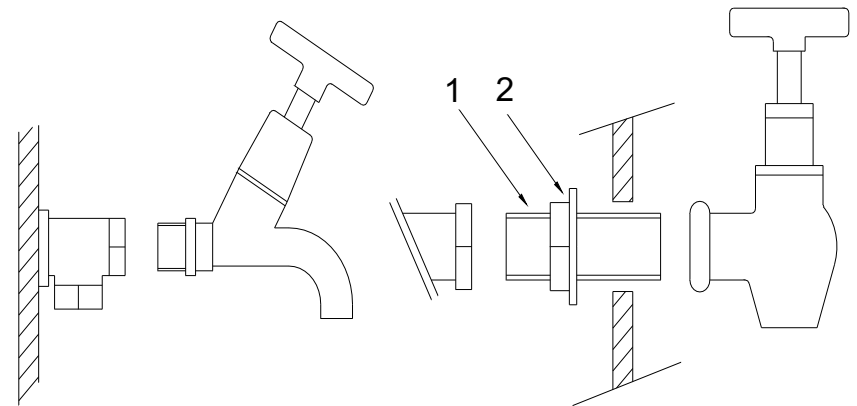

**N.B. Please write the name and product code of your fitting in the spaces provided on the back page. This will ensure a speedier service if you should need to phone the help line.**

## AFTERCARE INSTRUCTIONS

Your fitting has a high quality finish and should be treated with care to preserve the visible surfaces.

All surface finishes will wear if not cleaned correctly, the only safe way to clean your mixer is to wipe with a soft damp cloth. Stains can be removed using washing up liquid. All bath cleaning powders and liquids will damage the surface of your fitting, even the non-scratch cleaners.

**NOTE: Never use abrasive detergents or disinfectants or those containing alcohol, hydrochloric acid or phosphoric acid.**

Bristan recommend E-Cloth for cleaning all of our bathroom & kitchen products. Using just water, E-cloth gives a smear free, deep clean by breaking up and holding dirt, which normal cloths leave behind. Order through your Bristan stockist. (ORDER CODE: E-CLOTH)



## CLEANING / SERVICING

The hardness of the water in your area will determine how often you should clean and service this product.

Please refer to the Map of Hard Water Areas, on the following page.

## MAINTENANCE

**Sureflow** type valves: - If the fitting self-opens

1. Remove fitting head.
2. Tighten gland nut on top of valve.

**Traditional** type valves: - If the fitting leaks from the spindle

1. Remove fitting head (if necessary).
2. Tighten gland nut on top of valve.

**All valve types:** - If the fitting begins to drip

1. Turn off the water supply.
2. Remove fitting head and valve.
3. Carefully clean seating and rubber washer.
4. Replace valve and turn on the water supply.
5. Contact our helpline if problem persists.

## Map of Hard Water Regions in the UK



Soft to moderately soft  
0 - 100mg/l as calcium carbonate equivalent



Hard to very hard  
Above 200mg/l as calcium carbonate equivalent

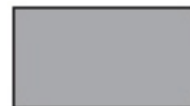

Slightly hard to moderately hard  
100 - 200mg/l as calcium carbonate equivalent

