

Datasheet

H-Series Motorised Valves

Rotary-Shoe and Paddle Types

Features



The H-Series Motorised Valves, working in conjunction with time controls and thermostats, are used in domestic and commercial central heating, hot water and chilled water systems to control the flow of water in the system.

They are designed and built for long term operation under arduous conditions of high temperatures and rapid pressure fluctuations.

These valves are developed to provide robustness, dependability and operating efficiency. Designed to withstand higher-than-usual test pressures, support bearings at both top and bottom of the shoe and paddle spindles and tough polycarbonate actuator covers are some of the features which ensure this added quality.

H-Series valves are normally purchased as separate valve bodies and actuators, but are

available as sets for some of the more popular combinations, see Product Selection Guide for details. Actuators are fitted to the valve bodies on site for convenience of installation and serviceability.

Available as either rotary-shoe or paddle types, H-Series valves offer the specifier and installer whatever he decides is appropriate for the job. The range includes 2-port, 3-port diverter or mid-position, metric sizes 15mm, 22mm and 28mm with copper compression fittings and imperial sizes 3/4" and 1" BSP threaded.

- Suitable for heating and cooling applications
- Proven reliability
- Long working life
- Actuators and valve bodies supplied separately for convenience
- Easy installation and wiring
- Industry-standard fittings and wiring colours
- Robust construction

Datasheet

H-Series Motorised Valves

Valve/Actuator Configuration

2-Port Valves

3-Port Diverter Valves

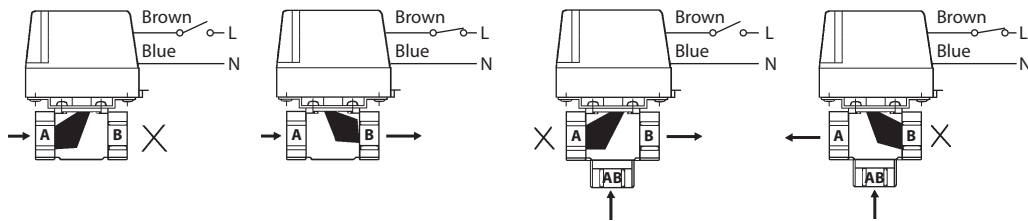

3-Port Mid-Position Valves

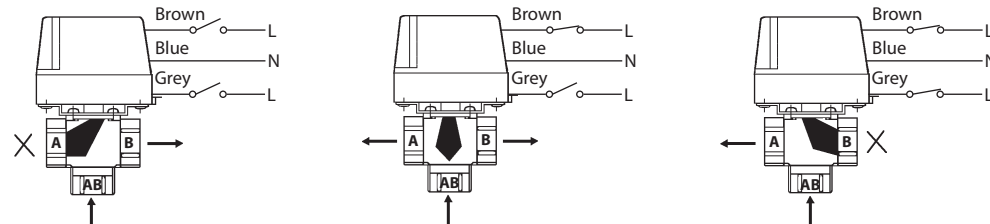

Ordering Codes

Valve Bodies Only

Type	Order Code	Size	Description	Kv (m ³ /hr)	Max. Differential Pressure (Bar)
Paddle Valves - 2 Port					
HPV22B	087N6622	22mm	External compression	5.8	1.0
HPV28B	087N6624	28mm	External compression	7.9	0.7
Paddle Valves - 3 port					
HSV3B22	087N6625	22mm	External compression	6.1	1.0
HSV3B28	087N6630	28mm	External compression	7.9	0.7
Shoe Valves - 2 Port					
HPV15	087N6596	15mm	Internal compression	3.3	1.0
HPV22	087N6597	22mm	External compression	8.2	1.0
HPV28	087N6598	28mm	External compression	15.0	0.7
HPV0.75	087N6594	3/4"	BSP	8.2	1.0
HPV1.0	087N6595	1"	BSP	15.0	0.7
Shoe Valve - 3 Port					
HSV3	087N6599	22mm	External compression	6.8	1.0

Note: All valve bodies can be used in chilled water applications using 60/40% Glycol/Water mix.

Valve Body and Actuator Complete

Type	Order Code	Size	Description	Kv (m ³ /hr)	Max. Differential Pressure (Bar)
Paddle Valves - 2 Port					
HP22B	087N6642	22mm	External compression	5.8	1.0
HP28B	087N6644	28mm	External compression	7.9	0.7
Paddle Valves - 3 Port - Mid Position					
HS3B	087N6646	22mm	External compression	6.1	1.0
HS3B28	087N6651	28mm	External compression	7.9	0.7
Shoe Valves - 2 Port					
HP15	087N6608	15mm	Internal compression	3.3	1.0
HP22	087N6609	22mm	External compression	8.2	1.0
HP28	087N6611	28mm	External compression	15.0	0.7
HP0.75	087N6602	3/4"	BSP	8.2	1.0
HP1.0	087N6604	1"	BSP	15.0	0.7
Shoe Valve - 3 Port					
HS3D	087N6614	22mm	External compression	6.8	1.0
Shoe Valves - 3 Port - Mid Position					
HS3	087N6613	22mm	External compression	6.8	1.0

Actuators Only

Type	Order Code	Description	Aux. Sw. Details	Valve Body Compatibility		
				HPV... 2 port	HSV... 3 port as diverter	HSV... 3 port as mid-position
HPA2	087N6579	2 port, N.C. spring return actuator	SPST	.		
HSA3D	087N6589	3 port, diverter valve actuator	SPST		.	
HSA3CD	087N6588	3 port, diverter valve actuator	SPDT		.	
HSA3	087N6587	3 port, mid-position valve actuator	SPST (Int. linked)			.

Datasheet

H-Series Motorised Valves

Specifications

Valve Body Specifications	
Body and trims	Hot stamped or die cast brass
Top Seal Gasket	THK-Ethylene propylene
Spindle O Ring Seals	Flurobon Fluro-elastomer
Paddle Material (Paddle type)	Nitrile elastomer
Shoe Material (Shoe type)	Carbon filled PTFE
Max. Working Pressure (Bar)	10.0
Max. Operating Temperature (°C)	95
Maximum bypass/leakage through closed port (shoe valves only)	15mm (inc. 1/2") & 22mm (inc 3/4") - 1 lt/hr @ 1 Bar Differential Pressure 28mm (inc 1") - 1 lt/hr @ 0.7 Bar Differential Pressure
Valve Actuator Specifications	
Voltage Rating*	220/240 Vac, 50/60Hz
Maximum Power Consumption	6 watts
Maximum Ambient Temperature	45°C
Opening Time	< 35 seconds
Closing Time	< 20 seconds
Auxiliary Switch Rating (if fitted)	3 (1) A, 220/240 Vac, 50/60 Hz
Enclosure Rating	IP40

Actuator Wiring Detail (Three-Port)

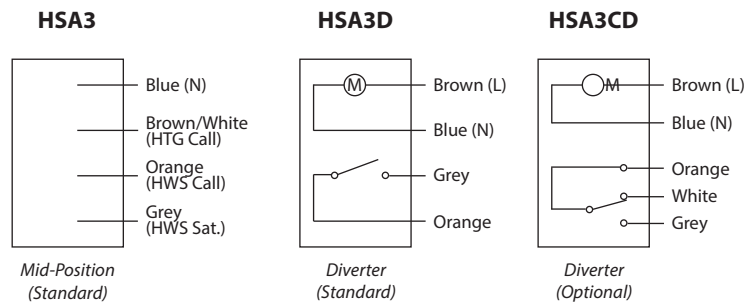

Actuator Wiring Detail (Two-Port)

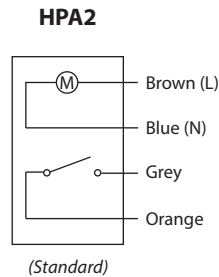

Sizing

The pressure drop across an H Series valve can be determined from this Kv diagram. The chart, which shows the Kv values of all H Series valves as diagonal lines, can be used to determine pressure drop when the flow rate is known (m³/h). It can also be used to read off pressure drop values when the heating load (kW) is known. A vertical axis, scaled in kW for systems working at temperature differences of either 11°C or 20°C, is included in the chart. Alternatively, pressure drop values can be calculated using the formula:

$$\Delta P = \left(\frac{Q}{K_v} \right)^2$$

Where:

- Q = Flow rate (m³/h)
 - Kv = Co-efficient of Flow (m³/h)
 - ΔP = Pressure Drop across the valve (bar)
- Kv values of each valve type and size are shown in the table opposite.

Examples of chart use:

- 1) To determine the pressure drop across a 22mm. 3-port paddle valve (Kv = 6.1), at a flow rate of 2.0 m³/h, follow the horizontal line from the 2.0 m³/h point on the left-hand vertical axis until it crosses the diagonal 6.1 Kv line.

By following a vertical line downwards from this point, a pressure drop of 0.11 bar can be read off the horizontal axis at the base of the chart.

- 2) To determine the pressure drop across a 22mm. 2-port paddle valve (Kv = 5.8), for a 20 kW heating load in a system working at an 11°C temperature difference, follow the horizontal line from the 20 kW point on the appropriate right-hand vertical axis until it crosses the diagonal 5.8 Kv line. By following a vertical line downwards from this point, a pressure drop of 0.072 bar can be read off the horizontal axis at the base of the chart.

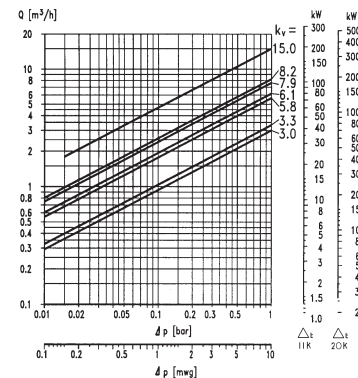

Datasheet

H-Series Motorised Valves

Dimensions

3-PORT

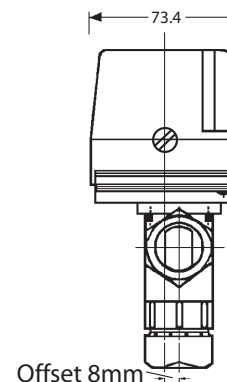
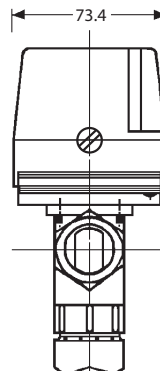
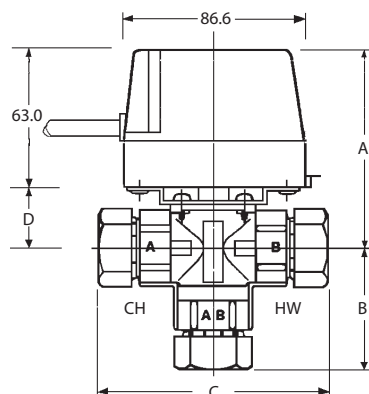

2-PORT

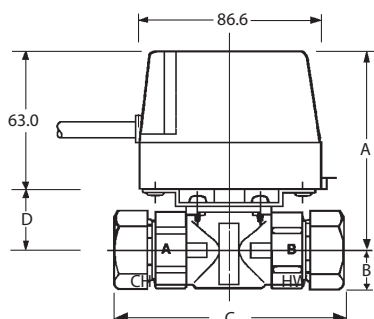

Shoe Valves

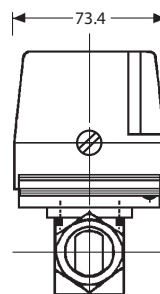

Paddle Valves

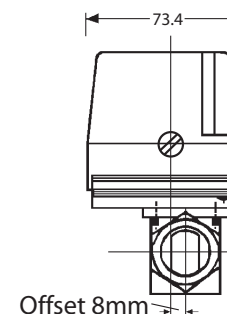

Valve Body	Connections	A	B	C	D
Paddle Valves					
Two-Port					
HPV22B	22mm Ext. Comp.	90.6	17.5	112.5	27.6
HPV28B	28mm Ext. Comp.	90.6	22.4	128.0	27.6
Three-Port					
HSV3B22	22mm Ext. Comp.	90.6	57.0	112.5	27.6
HSV3B28	28mm Ext. Comp.	90.6	71.5	128.0	27.6
Shoe Valves					
Two-Port					
HPV15	15mm Int. Comp.	87.1	13.8	83.5	24.1
HPV22	22mm Ext. Comp.	90.4	17.5	110.0	27.4
HPV28	28mm Ext. Comp.	93.6	24.3	108.0	30.6
HPV0.75	3/4" BSP	90.5	17.0	77.5	27.5
HPV1.0	1" BSP	93.6	20.6	87.3	30.6
Three-Port					
HSV3	28mm Ext. Comp.	90.7	56.0	110.0	27.7
All dimensions are shown in millimetres. Valve bodies and actuators may be purchased separately for ease of installation and serviceability, or in convenient sets. Actuators are fitted to valve bodies on site.					

Danfoss A/S

Climate Solutions • danfoss.com • +45 7488 2222

Any information, including, but not limited to information on selection of product, its application or use, product design, weight, dimensions, capacity or any other technical data in product manuals, catalogues descriptions, advertisements, etc. and whether made available in writing, orally, electronically, online or via download, shall be considered informative, and is only binding if and to the extent, explicit reference is made in a quotation or order confirmation. Danfoss cannot accept any responsibility for possible errors in catalogues, brochures, videos and other material. Danfoss reserves the right to alter its products without notice. This also applies to products ordered but not delivered provided that such alterations can be made without changes to form, fit or function of the product.

All trademarks in this material are property of Danfoss A/S or Danfoss group companies. Danfoss and the Danfoss logo are trademarks of Danfoss A/S. All rights reserved.