

Data Sheet

Danfoss Eco™

Programmable radiator thermostat for smartphone

Application



Danfoss Eco™ is a stand-alone radiator thermostat for residential use.

Danfoss Eco™ is battery powered, compact and easy to operate with a manual hand wheel and single button. Danfoss Eco™ is programmed with a smartphone App using Bluetooth connectivity.

Danfoss Eco™ is easy to install, in just 30 seconds! Adapters are available for all thermostatic valves manufactured by Danfoss and most other radiator valve manufacturers.

Features:

- Easy App programming via Bluetooth on smart phone or tablet
- Energy savings
- Easy to install
- Easy to operate
- Manual mode
- Open-window function
- PID Accurate temperature control
- Adaptive learning
- Night & day set-back, Weekly scheduling, Holiday and Pause
- Easy to read LCD display
- Display rotation -180 degrees
- Min./max. temp. range
- Child lock
- Frost protection

Ordering

	Language	Adapters (included)	Code no.
Danfoss Eco™ Installer Pack	FR, ES, IT, SE, PT, BG, NL, FI, LT, LV, EE, SK, NO, SI, HR, RO, HU, CZ, PL, TR, UA, UK	RA, M30	014G1001
Danfoss Eco™ Retail Pack	UK, DE, CH, AT, DK, FR, IT, PL, CZ	RA, M30, RAVL, RAV	014G1115



Data Sheet

Danfoss Eco™ Programmable Radiator Thermostat

Accessories

Type	Code no.
Adapters for RAV and RAVL valves	014G0250
Adapter for RA valves	014G0251
Adapter for K (M30 x1.5) valves	014G0252
Adapter for RTD valves	014G0253
Adapter for M28 MMA valves	014G0264
Adapter for M28 Herz valves	
Adapter for M28 COMAP valves	
Adapter for M28 Orkli valves	014G0257
Adapter for Caleffi valves	014G0263
Adapter for Giacomini valves	

Specifications

Thermostat type	Programmable electronic radiator valve controller
Recommended use	Residential (pollution degree 2)
Actuator	Electromechanical
Display	LCD with white backlight
Software classification	A
Control	PID
Power supply	2 x 1.5 V alkaline AA batteries
Power consumption	3 mW in standby, 1.2 W when active
Transmission Frequency / Power	2,4 GHz / <2,1mW
Battery life	Up to 2 years
Low battery signal	Battery icon will flash in display. If battery level is critical the red ring will flash.
Ambient temperature range	0 to 40 °C
Transportation temperature range	-20 to 65 °C
Maximum water temperature	90 °C
Temperature setting range	4 to 28 °C
Measurement interval	Measures temperature every minute
Clock accuracy	+/- 10 min/year
Spindle movement	Linear, up to 4.5 mm, max. 2 mm on valve (1 mm/s)
Noise level	<30 dBA
Safety classification	Type 1
Open-window function	Activated at temperature decrease
Color	RAL 9016
Weight (incl. batteries)	198 g (with RA adapter)
IP class	20 (not to be used in hazardous installations or in places where it will be exposed to water)
Approvals, markings etc.	  

App Advanced Settings



The App allows free selection of temperatures for 'At Home', 'Away/Asleep' and Vacation. Schedules allow for up to 3 setback periods per day and unique schedules as needed throughout the week.



If Danfoss Eco™ is not paired to a smartphone then the default schedule will be used until the manual wheel is turned.



When selected on the App, the Danfoss Eco™ will control temperature according to the programmed Vacation temperature. It is possible to select a Vacation temperature between 5 and 28 °C.



Pause setting - Danfoss Eco™ has been turned down to minimum temperature manually or on App home screen, a center icon switches to Pause.

Measuring the room temperature

Danfoss Eco™ is measuring the temperature with multiple built-in sensors to ensure accurate control. Based on these readings the room temperature is calculated for an area approx. 20cm in front of the display. This allows Danfoss Eco™ to control the actual room temperature very accurately.

Be aware that sources of cold or heat, e.g. fireplace, direct sun or draft, might affect the function of Danfoss Eco™.

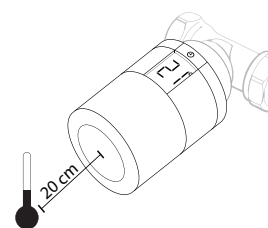

Note: The displayed temperature is always the set temperature, not the actual room temperature.

Main features

App Scheduling

Easy App programming via Bluetooth on smart phone or tablet. Up to 3 setback periods per day and the option to copy the schedule across to other days.

Software Updates

Software updates are automatic, prompted via the App. The data security of the Danfoss Eco™ thermostat and App that is paired to your smartphone is guaranteed. The system is tested by independent specialists.

Open-window function

Danfoss Eco™ features an Open-window function, which closes the valve if the room temperature is falling dramatically, thus reducing the heat loss. The radiator heat is shut off for up to 30 minutes, before Danfoss Eco™ returns to its original settings. When Open-window has been activated, the function is quarantined for 45 minutes.

Adjusting to the valve

During the first night of operation Danfoss Eco™ will shut off the radiator heat and then open again to detect the exact opening point of the valve. This will allow Danfoss Eco™ to control the heat as efficiently as possible. If necessary, the procedure is repeated once a night for up to a week.

You might experience the valve being warm during the adjustment procedure, regardless of the room temperature.

Child lock

Activating the child lock feature will protect the settings from tampering.

Adaptive learning

During the first week of operation Danfoss Eco™ learns when it is necessary to start heating the room in order to reach the correct temperature at the correct time.

The intelligent control will continuously adjust the heating time compared to seasonal temperature changes.

Automatic valve exercising

To keep the radiator valve functional and at its best, Danfoss Eco™ automatically exercises the valve every Thursday at approx. 11:00 hrs by fully opening and then returning to its normal setting.

Installation

1. Start by mounting the appropriate adapter. Identify the needed adapter with the adapter guide.

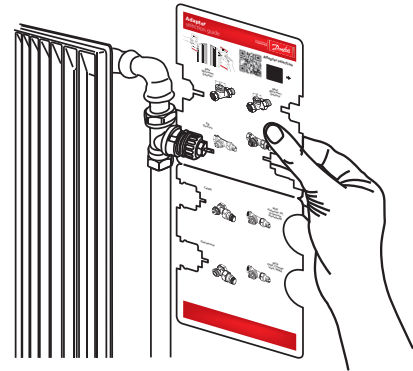

Adapters

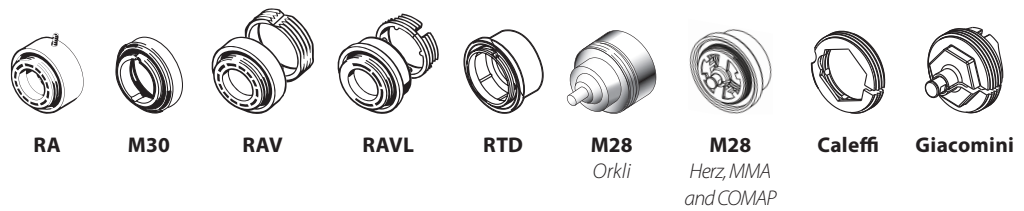

2. Insert the batteries, then mount the thermostat onto the adapter by turning it until you hear a click.

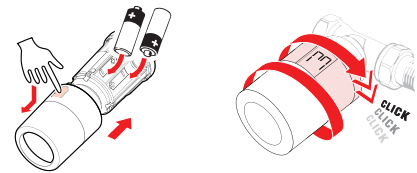

3. Press and hold the button for 3 seconds. The Danfoss Eco™ is now mounted and will display the current temperature.

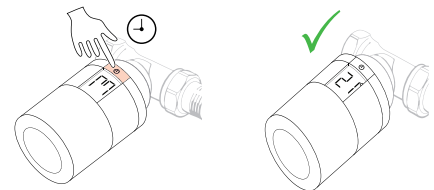

4. Download the Danfoss Eco™ App from Apple App Store or Google Play Store.



Search Danfoss Eco™ or follow the link:-



Dimensions

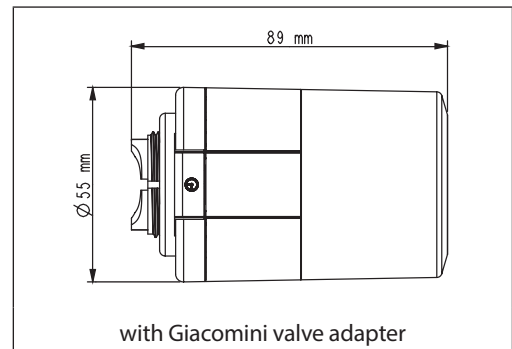
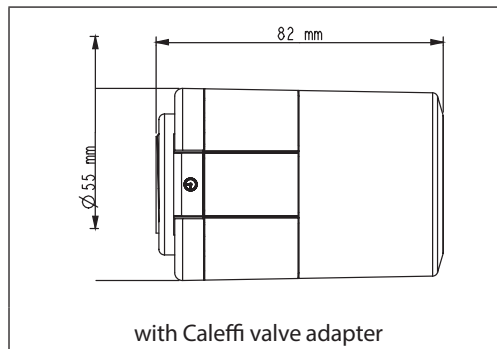
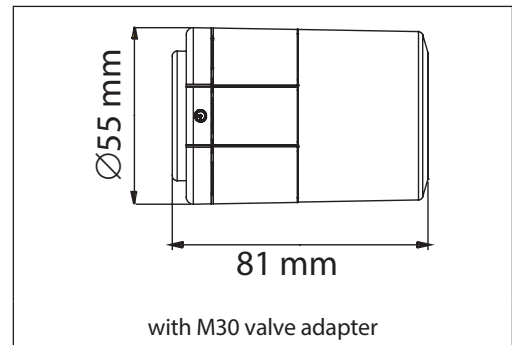
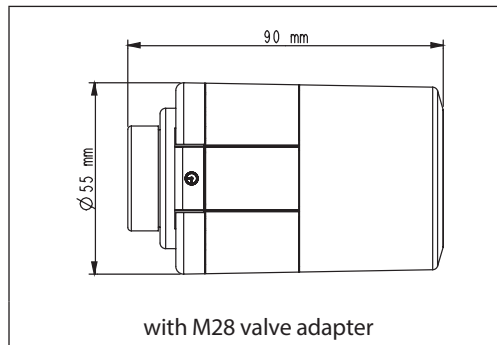
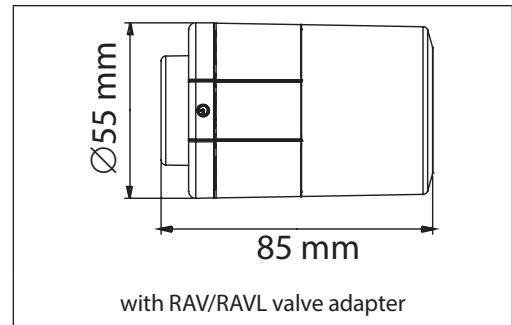
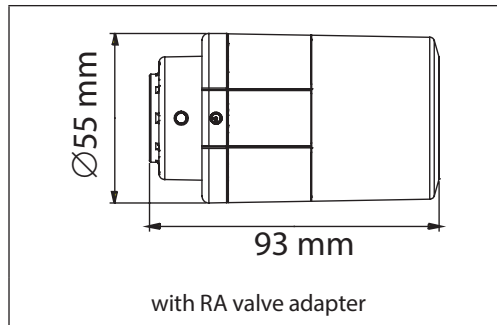

Danfoss A/S

Climate Solutions • danfoss.com • +45 7488 2222

Any information, including, but not limited to information on selection of product, its application or use, product design, weight, dimensions, capacity or any other technical data in product manuals, catalogues descriptions, advertisements, etc. and whether made available in writing, orally, electronically, online or via download, shall be considered informative, and is only binding if and to the extent, explicit reference is made in a quotation or order confirmation. Danfoss cannot accept any responsibility for possible errors in catalogues, brochures, videos and other material. Danfoss reserves the right to alter its products without notice. This also applies to products ordered but not delivered provided that such alterations can be made without changes to form, fit or function of the product.

All trademarks in this material are property of Danfoss A/S or Danfoss group companies. Danfoss and the Danfoss logo are trademarks of Danfoss A/S. All rights reserved.