

Technical Datasheet

Product Code: SY-ANGELCIST

Product Description: Angel Cistern cw Fittings



Specification

Product Guarantee:	Lifetime
Packaged Weight (kg):	14 kg
Material:	Ceramic
Style:	Modern
Flush Type:	Push Button
Cistern Flush:	Dual Flush



Key Features

- Pure & luxurious modern design ideal to boost your bathroom décor
- The natural raw materials make ceramic hard wearing, scratch-proof & resistant to limescale
- Features dual flush function for less water consumption
- Compatible close coupled pans are available in this range
- Complete with fittings

Technical Drawing

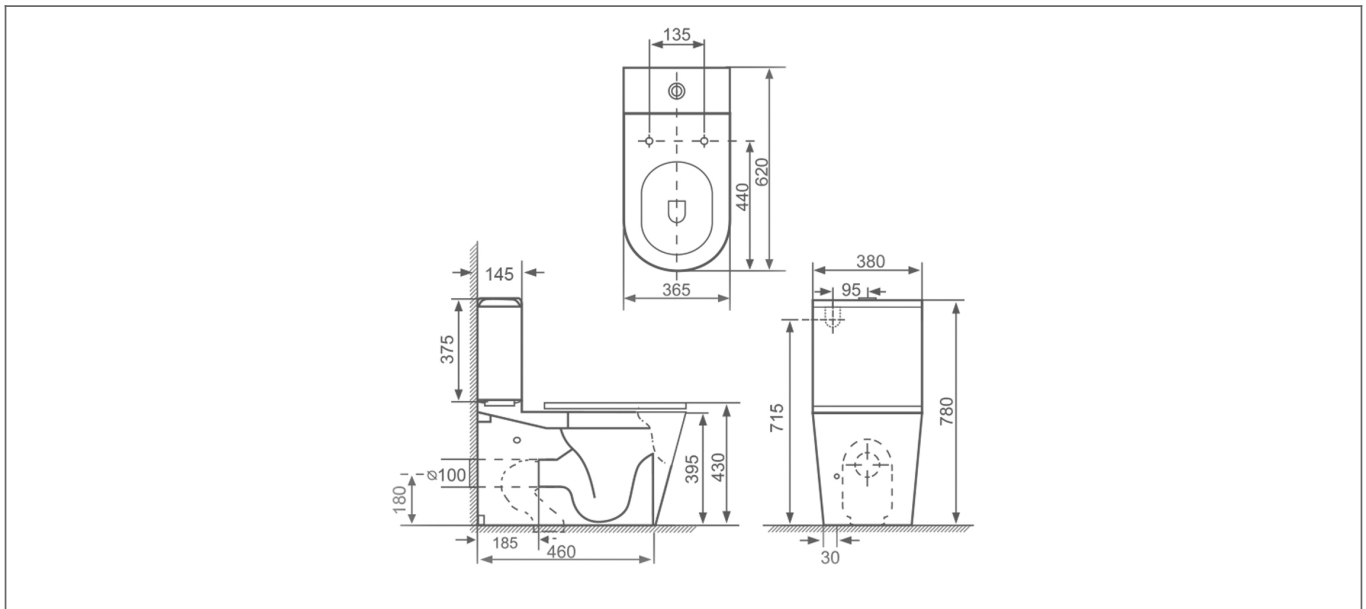

Dimensions: All measurements are in millimetres and are subject to normal manufacturing variations.

Due to a continuing development programme to improve design and performance, we reserve all rights to vary specifications without prior notice. Please note, all accessories are for photographic purposes only.