

## Warranty Information\*

Your product comes with the following warranty:

Valve - 5 years. This includes 2 years parts and labour followed by a further 3 years parts only,

Rail Kit and accessories - 1 year parts only. Proof of purchase will be required.

Satinjet® Kiri Low Flow Handset - Lifetime warranty

The guarantee does not cover faults or damage caused by incorrect installation and/or maintenance, ordinary wear and tear, water composition, etc.

\*Please see [www.methven.com](http://www.methven.com) for full terms and conditions of warranty

Please retain installation & maintenance guide for future reference.

## Cleaning

Your product has a high-quality finish and should be treated with care to preserve the visible surfaces. Never use abrasives or abrasive cleaning agents to clean this product. Clean regularly with contamination free warm water and a damp soft cloth. Do not use products containing chlorine bleach or hydrochloric acid as these can damage the product.

We have a policy of continuous improvement and reserve the right to change specifications without notice.

METHVEN UK LIMITED  
METHVEN EXPERIENCE CENTRE  
3/3A STONE CROSS COURT YEW TREE WAY  
GOLBORNE  
WARRINGTON  
WA3 3JD  
UNITED KINGDOM

INST -KLFCTSEFCP

17.05.2022

16

TEL: 0800 195 1602  
FAX: 0844 406 8690  
EMAIL: [sales@uk.methven.com](mailto:sales@uk.methven.com)  
[www.deva-uk.com](http://www.deva-uk.com)  
[www.methven.com](http://www.methven.com)

# Kiri Low Flow Bar Shower with Easy Fit Kit

## KLFCTSEFCP

## Installation Guide

---

### Technical Specification

#### Supply:

Suitable For High Pressure Systems

#### Working Pressure:

Min: 1.0 Bar

Max: 5.0 Bar

#### Operating Temperature:

Hot: 65°C

Cold: 5°C

#### Inlet Connections:

15mm Compression

#### Cartridge/Valve Type:

Thermostatic

#### Operation:

Separate Flow and Temperature Controls

#### Features:

- Safe cool touch body
- 38°C hot stop with override facility
- Includes easy fit connections
- Smooth easy clean 1.5m hose
- Riser rail features adjustable brackets - ideal for retrofit
- Includes Kiri Satinjet® Low Flow handset - Water efficient -save water, save energy



**METHVEN**  
[www.methven.com](http://www.methven.com) EST 1886

Congratulations on your purchase of your new Methven Kiri Low Flow Bar Shower with Easy Fit Kit. Our fitting instructions have been created with you in mind to provide you with all the information you require. If you need any further help, please don't hesitate to contact our customer care team on 0800 195 1602.

**Please keep these instructions for future reference and request of replacement parts.**

**INSTALLERS – Ensure these instructions are left with the end user.**

## General Safety Information:

**IMPORTANT:** Please read all the instructions before installation. Methven recommends this product is installed by a licensed plumber in compliance with all relevant Water Authority Regulations, Water Supply (water fittings) regulations 1999. If you are unsure as to what the regulations require, you can contact your Local Water Authority or the institute of Plumbers for further details.

This product is safe provided it is installed, used and maintained in accordance with these instructions and recommendations.

Prior to installation you should fully flush the system to ensure there is no debris in the system that could cause damage to the product.

This product **must** not be modified in any way as this will invalidate the guarantee.

It is the responsibility of the installer to ensure a waterproof seal is achieved, after installation all connections must be checked for leaks.

All outlets used primarily for personal hygiene shall deliver water at a safe temperature as per regional regulations.

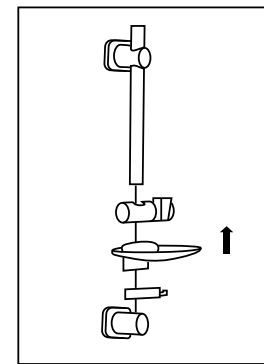

2. Assemble the handset slider, soap dish and hose retainer on to the rail ensuring button is facing upward. Attach both rail end assemblies.

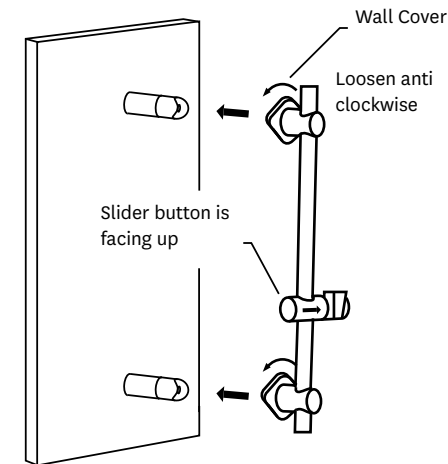

3. Ensuring the handset slider button is facing upwards as shown in the illustration, adjust the two rail end assemblies to match the position of the wall brackets and turn wall covers anticlockwise to the unlock position.

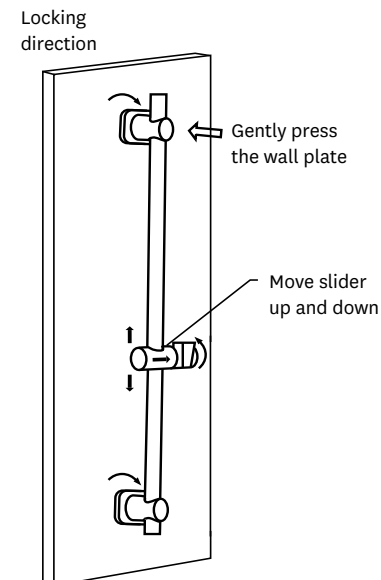

4. Gently press the rail end assemblies onto the wall brackets, until the rail ends touch the wall. Turn both wall covers clockwise into the locking position, securing the rail. Adjust handset slider to desired height for showing.

## Installation of the Shower Kit:

Line Drawing: Unit of measure = mm's

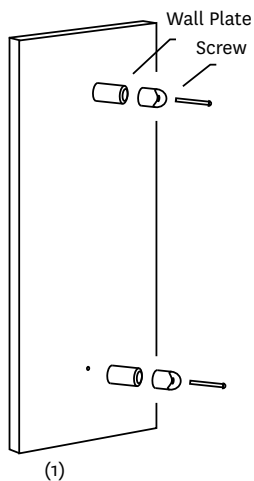
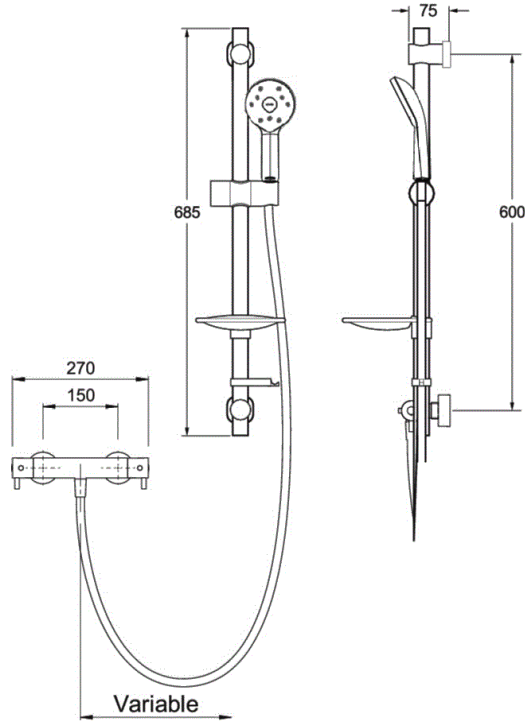

1. Use a 6mm drill bit to drill a hole in the wall at the desired height, drill a second hole vertically lower at a recommended height of 550mm. In certain situations, the hole may need to be further away to a maximum of 615mm. Place wall plugs into hole and push firmly into place. Place fixing bracket over the wall plugs (1) and insert screw provided, tighten until secure, repeat for second fixing bracket. Push rubber grip into fixing bracket aligning the groove vertically (2)

## Operating Specifications:

Do not choose a position where the thermostatic bar valve could become frozen.

Do not allow the inlet pressure or flow rates to operate outside the operating conditions

Do not connect the thermostatic bar valve to a gravity hot supply and a mains cold supply or vice versa.

Do not subject the thermostatic bar valve to a water temperature above 85°C during installation, use, maintenance or disinfection.

Do not use jointing compounds on any pipe fittings for the installation

Do not solder fittings near the unit as heat transfer along the pipework could damage the bar valve.

The layout and sizing of pipework must be such that nominally equal inlet supply pressures are achieved, and the effects of other draw-offs are minimized.

The hot water pipe entry must be made to the left-hand side inlet, marked with a red dot.

Suitable isolating valves (complying with Water Regulations and Bylaws) must be fitted on the hot and cold water supplies as close as practicable to the inlets of the thermostatic bar valve. These isolating valves must be accessible to provide an independent means of isolating the water supplies should maintenance or servicing be necessary.

Before connecting the thermostatic bar valve, water should be flushed through the system to remove all debris that might otherwise damage the valve.

## TMV2 Operating Specifications:

This Thermostatic Shower Mixer Valve is suitable for All Pressure water heating systems provided it is installed correctly. If a water supply is fed by gravity then the supply pressure should be verified to ensure the conditions of use are appropriate for the valve.

	High Pressure
Maximum Static Pressure - Bar	10 bar
Flow Pressure, Hot & Cold - Bar	0.5 to 5.0
Hot Supply Temperature - °C	55°C to 65°C
Cold Supply Temperature - °C	<25°C

**NOTE:** Valves operating outside these conditions cannot be guaranteed by the scheme to operate as Type 2 valves. Operating pressure on hot and cold line should be kept as balanced as possible in order to assure maximum efficiency. The valves designation of use is HP-S suitable for High Pressure BS EN1111 application.

### Recommended outlet temperatures:

The NSF TMV Scheme recommends the following set maximum mixed water outlet temperatures for use in all premises:  
41°C for showers

The mixed water temperature must never exceed 46°C

The maximum mixed water temperature can be 2°C above the recommended maximum set outlet temperatures.

### Temperature Setting:

The mixer has been set in the factory under balanced pressures at 38°C. Where conditions are different from the above the temperature of the mixed water may vary from setting. You can adjust the calibration of the mixer to suit individual requirements.

**46°C is not a safe bathing temperature for adults or children.**

## Troubleshooting:

Symptom	Cause(s)	Resolution
Maximum water temperature too hot or cold	Maximum water temperature set incorrectly.	Reset maximum water temperature. Refer to 'Setting/Commissioning' sections
Outlet water temperature too hot / cold.	Inlet filter is partially blocked.	Check insert filters for any blockages and clean as necessary
	Installation conditions outside operating parameters.	Refer to Installation Requirements (pages 6-8). Service shower valve as recommended. Refer to commissioning section (page 10).
Water temperature too cold – maximum water temperature incorrectly set.	Instantaneous water heater not igniting because water flow rate is too low.	Increase water flow rate through the system. Check cartridge inlet filters and clean or replace.
	Hot water temperature is less than 10°C above the required blend temperature.	Adjust hot water temperature or wait for water to reheat if stored system is used
	Instantaneous water heater not igniting because water pressure is too low.	Refer to General Information for system requirements. Increase water pressure through system.
Only hot or cold water from TMV outlet / Unable to set mid range temperature.	Inlet water supplies are reversed (hot to cold supply).	Check the connections are the correct way round. Hot on the left and cold on the right when viewed from the front. Rework pipework as necessary.
	Inlet filter is partially blocked.	Clean or replace, flush through pipework before refitting.

## Filter Washer Cleaning:

It is advised that this should be carried out by a qualified person.

1. Isolate both hot and cold mains supplies.
2. Undo the nuts on both hot and cold inlet unions and remove the filter washers.
3. Wash the filter washers thoroughly under running water. Use a suitable brush to remove all debris.
4. Refit into hot and cold inlets and tighten nuts.
5. Turn on hot and cold mains supplies and check for leaks.

The British Burns Association recommends 37°C to 37.5°C as a comfortable bathing temperature for children. In premises covered by the Care Standards Act 2000, the maximum mixed water outlet temperature is 43°C.

The thermostatic mixing valve will be installed in such a position that maintenance of the TMV and it's valves and the commissioning and testing of the TMV can be undertaken. The fitting of isolation valves is required as close as is practicable to the water supply inlets of the thermostatic mixing valve. The fitting of strainers is recommended as close as is practicable to the water supply inlets of the thermostatic mixing valve.

## Installation of the Valve:

### Line Drawing:

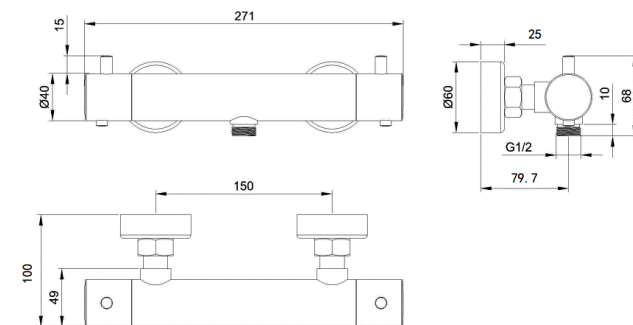

**Important points to note before commencing installation of your bar shower mixer.** You should:

- Check the contents of the box and all parts are present and correct.
- Check to ensure the minimum operating conditions can be met.
- Have the correct tools to perform a trouble free installation.
- Considered the surrounding environment where the installation is to take place and any potential hidden dangers.
- Isolate both the hot and cold water supplies.

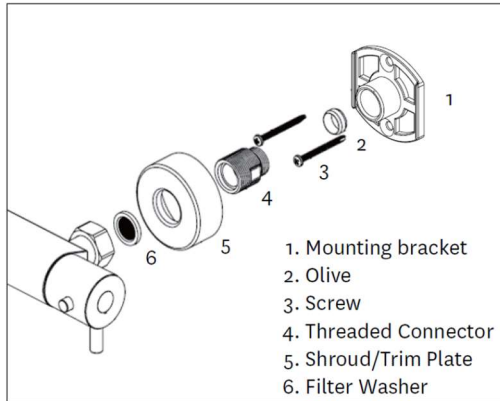

1. Prepare the hot and cold supply pipes at 150mm centres.
2. Ensure the holes for the pipes are not made too big as this will affect drilling of the screw holes for the mounting brackets.
3. Ensure that there is approximately 22mm of pipework left exposed proud of the finished tiled wall to establish the correct installation connection.

4. Apply an appropriate amount of sealant between the pipe and wall lining to create a watertight seal.

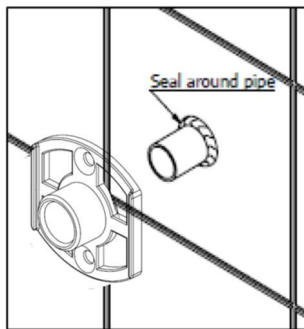

It is the responsibility of the installer to ensure a waterproof seal is achieved between the product and mounting surface.

5. Place the mounting plate over the pipework
6. Place the olive over onto the exposed pipe.
7. Take one of the threaded connectors, slide the connector over the pipework and loosely fit the threaded connector into the mounting bracket. This will ensure that the pipework is central to the mounting bracket.
8. Using the mounting bracket as a template, mark the positions of the holes to be drilled.
9. Remove the threaded connector, slide the mounting bracket and olive off the pipework.
10. Drill and plug the wall in position as previously marked, Note: Ensure you use the correct type of wall plugs to suit your particular installation conditions.

6. Record the equipment, thermometer etc. used for the measurements If at step (5) the final mixed water temperature is greater than the values in the table and/or the maximum temperature exceeds the corresponding value from the previous results by more than about 2, the need for service work is indicated.

If there is a residual flow during the commissioning or the annual verification (cold water supply isolation test), then this is acceptable providing the temperature of the water seeping from the valve is no more than 2°C above the designated maximum mixed water outlet temperature setting of the valve. Temperature readings should be taken at the normal flow rate after allowing for the system to stabilize.

Depending on the results of the above tests, several possibilities exists:

- a. If no significant change (e.g. <1) in mixed water temperatures are recorded between commissioning and 6-8 week testing, or between commissioning and 12-15 weeks testing the next in-service test can be deferred to 24-28 weeks after commissioning.
- b. If small changes (e.g. 1-2) in mixed water temperatures are recorded in only one of these periods, necessitating adjustment of the mixed water temperature, then the next in-service test can be deferred to 24-28 weeks after commissioning.
- c. If small changes (e.g. 1-2) in mixed water temperatures are recorded in both of these periods, necessitating adjustment of the mixed water temperature, then the next in-service test can be carried out at 18-21 weeks after commissioning.
- d. If significant changes (e.g. >2) in mixed water temperatures are recorded in either of these periods, necessitating service work, then the next in-service test should be carried out at 18-21 weeks after commissioning.

The general principle to be observed after the first 2 or 3 in-service tests is that the intervals of future tests should be set to those which previous tests have shown can be achieved with no more than a small change in mixed water temperature.

## In Service Testing:

### Purpose

The purpose of in-service test is to regularly monitor and record the performance of the thermostatic mixing valve. Determination in performance can indicate the need for service work on the valve and/or the water supplies.

### Procedure

Using the same measuring equipment or equipment to the same specification as used in the commissioning of the valve, adjust the temperature of the mixed water in accordance with the manufacturer's instructions and the requirement of the application. Carry out the following sequence:

1. Record the temperature of the hot and cold water supplies.
2. Record the temperature of the mixed water at the largest draw-off flow rate.
3. Record the temperature of the mixed water at a smaller draw-off rate, which shall be measured.

If the mixed water temperature has changed significantly from the previous test result (e.g.>1) record the change and before re-adjusting the mixed water temperature check:

1. That any in-line or integral strainer are clean.
2. Any in-line or integral check valves or other anti-back siphonage devices are in good working order.
3. Any isolating valves are fully open.

With an acceptable mixed temperature, complete the following procedure:

1. Record the temperature of the hot and cold water supplies.
2. Record the temperature of the mixed water at the largest draw-off flow rate.
3. Record the temperature of the mixed water at the smaller draw-off flow rate, which shall be measured.
4. Isolate the cold water supply to the mixing valve and monitor the mixed water temperature.
5. Record the maximum temperature achieved as a result of (4) and the final stabilised temperature

11. Place the mounting bracket back over the pipework
12. Place the olive over onto the exposed pipe.
13. Take one of the threaded connectors. Ensure the end with the flat edges is facing towards the wall. Slide the connector over the pipework and loosely fit onto the mounting bracket.
14. Screw the mounting bracket to the wall
15. Using a spanner, located the flat edge on the threaded adapter and tighten onto the mounting bracket.

### To fix the second mounting bracket and ensure the bar valve is positioned squarely on the wall

16. Take the second mounting bracket in your hand and loosely fit the threaded connector. Take this loose assembly and screw this to the bar valve. **This will be used as a template to ensure that the correct centres are achieved and the thermostatic bar valve is installed squarely.**
17. Loosely screw the other bar valve connection to the mounting bracket assembly affixed to the wall previously, ensuring the second exposed pipe slides into the loosely assembled mounting bracket attached to the thermostatic bar valve.
18. Taking care not to damage the surface of the bar valve, use a spirit level to line up the bar valve squarely. Ensuring the mounting bracket is against the wall, use the mounting bracket as a template to mark the positions of the holes to be drilled and plugged.
19. Remove the shower mixer assembly from the wall.
20. Unscrew the loosely assembled mounting bracket and threaded connector from the thermostatic bar valve.
21. Drill and plug the wall in positions as previously marked.

### Ensure you use the correct type of wall plugs to suit your particular installation conditions.

22. Place the mounting bracket back over the pipe.
23. Place the olive onto the exposed pipe.
24. Take the remaining threaded connector. Ensure the end with the flat edges is facing towards the wall. Slide it over the pipe and loosely wind the threaded connector onto the mounting bracket.
25. Screw the mounting bracket to the wall

26. Using a spanner, locate the flat edge on the threaded adapter and tighten onto the mounting bracket.
27. To fit the trim plates, screw on to the threaded insert until it reaches the finished wall lining and align accordingly.

**At this stage the pipe should be flushed of any debris. Failure to do so may result in the filter of the bar valve becoming prematurely blocked and reduce its performance.**

28. Ensuring seals and filters washers are correctly located in the inlet unions of the bar valve, screw the unions of the bar valve to the easy fix connectors and tighten.
29. Turn on the hot and cold water supplies and check for leaks.

**\*\* For products featuring Rail, Handset and Hose – See section on Installation of the Shower Kit\*\***

## Commissioning:

As the installed supply conditions are likely to be different from those used in factory testing it is appropriate, at commissioning, to carry out some simple checks and tests on the thermostatic bar valve to provide a performance reference point for future verification.

Check that:

1. The designation of the thermostatic bar valve matches the intended application.
2. The supply pressures are within the thermostatic valve operating pressures.
3. The supply temperatures are within the thermostatic valve operating range

If all these conditions are met, proceed to check factory setting.

1. Start the water flow by rotating the flow control (right hand side) anticlockwise.
2. Make sure that the hot and cold water suppliers are fully open, at normal temperature and pressure and are within the requirements as stated

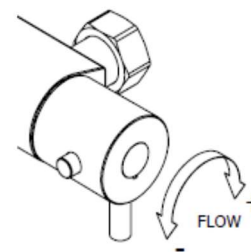

3. Make sure the temperature control is at the maximum temperature setting. This product has a temperature override button, to access temperature above the normal comfortable showering temperature, press the button and continue turning the handle.

4. Allow the shower to run at this

maximum temperature setting until the water temperature has stabilised.

5. A final temperature check should be made and that the mixed water temperature at the terminal fitting must never exceed 46°C.

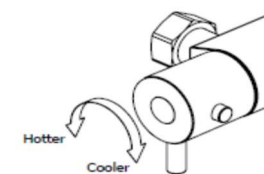

It is a requirement that all TMV2 approved valves shall be verified against the original set temperature results once a year to ensure continued good performance, failure to regularly maintain the Thermostatic mixing valve may lead to poor flow, fluctuations in temperature and in some cases complete failure.

The mixer has been set in the factory under balanced pressures at 38°C. Where conditions are different from the above the temperature of the mixed water may vary from setting. You can adjust the calibration of the mixer to suit individual requirements.

1. Turn temperature handle to fully hot.
2. Remove the handle cap and the screw and pull the handle from valve.
3. Turn the spindle on the thermostatic cartridge until the desired temperature is reached. (Always maintain the 10°C difference between supply and mixed).
4. Once the temperature is reached, replace the handle so that the stop is in the maximum position, replace screw and handle cap.

**Re-calibration should only be carried out when absolutely necessary.**