

DU144 Automatic Bypass Valve FOR HYDRONIC HEATING SYSTEMS

PRODUCT DATA



Design

The DU144 automatic bypass valve consists of:

- Valve housing with compression fittings for 22mm copper tube on inlet and outlet
- Spindle and plug assembly
- Bonnet with differential pressure setpoint marking
- Handwheel to pre-set differential pressure
- Protection cap

Materials

- Valve housing, pipe connections, plug, bonnet and handwheel made of brass
- Spindle made of stainless steel
- All sealings made of EPDM
- Protection cap made of red plastic

Application

The DU144 automatic bypass valve controls water flow in the heating circuit according to the water pressure across it and is used to maintain a minimum flow rate through the boiler and to limit circulation pressure when other water paths are closed.

A bypass circuit must be installed if the Boiler manufacturer requires one, or specifies that a minimum flow rate has to be maintained whilst the Boiler is firing.

The use of automatic bypass valves becomes particularly important when heating systems include large numbers of thermostatic radiator valves (TRVs) – whilst the TRVs are open the automatic bypass valve remains closed, however, as the TRVs start to close, the automatic bypass valve starts to open maintaining the required water flow through the boiler. Using an automatic bypass valve is also likely to reduce noise in systems caused by excess water velocities.

Because manual or fixed position valves do not regulate the flow and allow water to bypass even when it is not necessary, building regulations require bypass circuits to use automatic bypass valves and not fixed position valves.

Features

- Rugged design with protection cap
- Pre-settable differential pressure from 0.1 to 0.6 bar
- Factory set to 0.2 bar
- Equipped with compression fittings for 22mm copper pipe

Specifications

Medium	Water or water-glycol mixture, quality to VDI 2035
pH-value	8...9.5
Operating temperature	2...130°C (36...266°F)
Operating pressure	max. 10 bar (145 psi)
Differential pressure pre-setting range	0.1...0.6 bar (1.45...8.7 psi); factory setting: 0.2 bar (2.9 psi)
k_{vs} (cv)-values	2.3 (2.7)

Function

The DU144 automatic bypass valve is installed between the supply and return mains pipeline. The differential pressure is set according to the minimum flow required for the boiler and the available pump head.

When the differential pressure is reached, for example because of closing TRVs, the DU144 starts to open. As the

differential pressure increases across the valve the valve is further opened and the flow increased.

When the differential pressure decreases, for example because TRVs are opening again, the valve closes and the flow is redirected from the bypass to the heating loop.

Dimensions

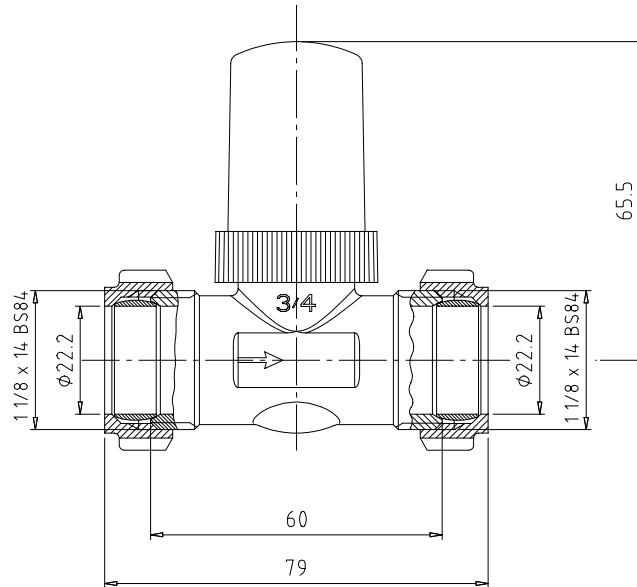

Fig. 1. DU144A1001

NOTE: The DU144 is supplied with compression fittings for 22 mm copper pipe.
All dimensions in mm.

Ordering Information

Table 1. OS-Nos. (OS=Ordering System)

Order text	Pre-setting range	OS-No.
DU144 automatic bypass valve	0.1...0.6 bar (1.45...8.7 psi)	DU144A1001

Application Examples

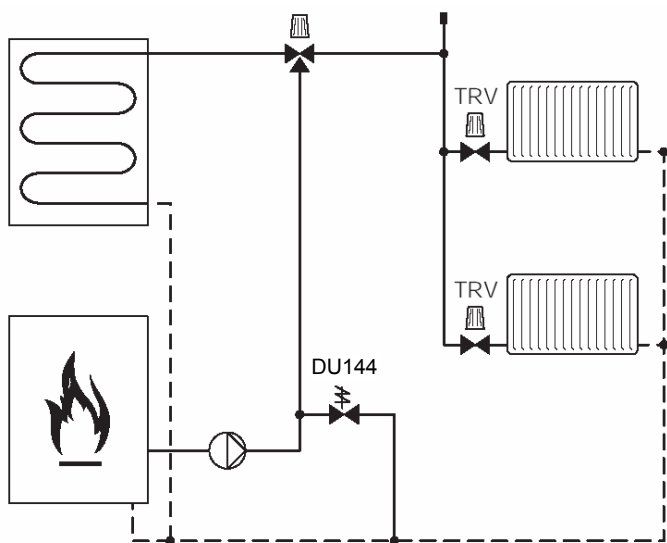

Fig. 2. DU144 in system with stored hot water

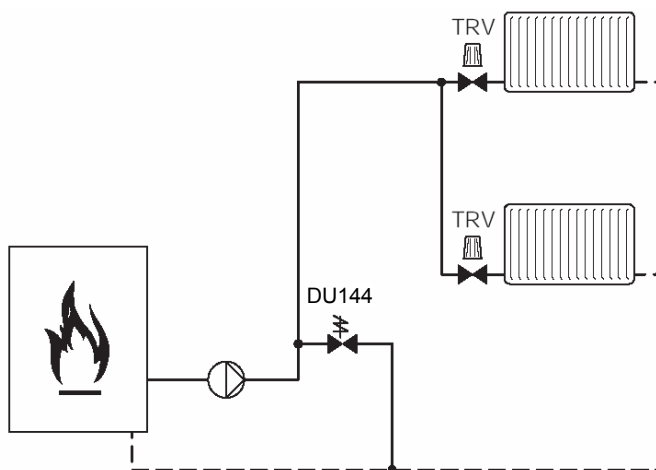
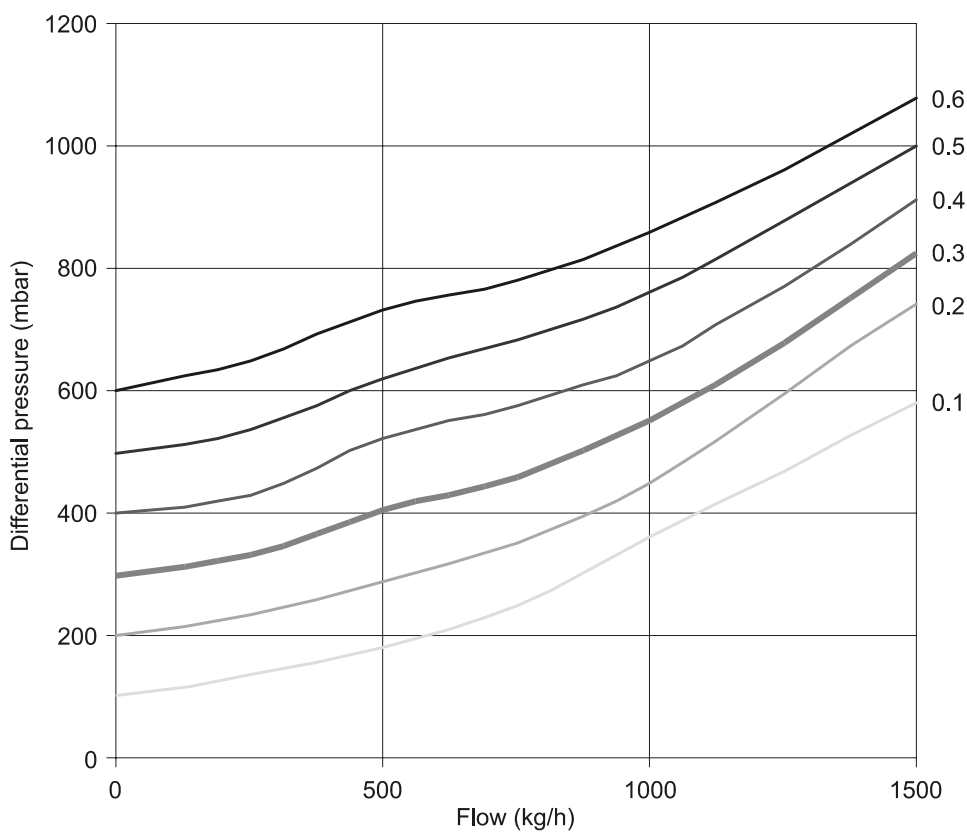

Fig. 3. DU144 in system with combi boiler

Flow Diagram



ACS Control Products

Honeywell GmbH

Möhnestraße 55

59755 Arnsberg, Germany

Phone: +49 (2932) 9880

Fax: +49 (2932) 988324

www.honeywell.com

EN0H-0322GE25 R1005

October 2005

© 2005 Honeywell International Inc.

Subject to change • All rights reserved

Manufactured for and on behalf of the Environmental and Combustion
Controls Division of Honeywell Technologies Sàrl, Ecublens,
Roude du Bois 37, Switzerland or by its Authorized Representative.

Honeywell