

Sales Code: LDR009

Description: Clevedon Radiator

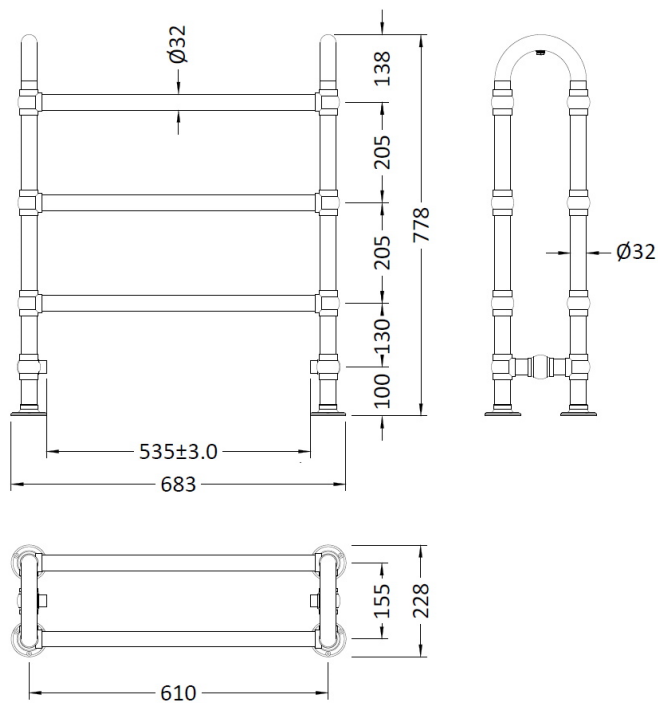

Product Dimensions

Height (mm):	778
Width (mm):	683
Depth (mm):	228
Length (mm):	
Nett Weight (kg):	11.8

Packaging Dimensions

Height (mm):	245
Width (mm):	705
Length (mm):	850
Gross Weight (kg):	13.3

Packaging Data

Box Colour:	White Cardboard Shrinkwrapped
Box Qty:	1
Label Size:	100 x 50
Label Colour:	White Label
Label Qty:	2

Outer Box Dimensions (If Applicable)

Height (mm):	
Width (mm):	
Length (mm):	
Gross Weight (kg):	
Barcode:	5055369036424

Product Details

Country of Origin:	China		
Fitting Instruction:	No		
Certification:	CE & UKCA: No	RoHS: N/A	WEEE: N/A
Colour/Finish:	Chrome		
RAL No:	N/A		
Product Material:	Steel		
Heat Element Wattage:	Not Applicable		
Heating Element Wattage Compatible:	N/A		
BTU Outputs:	30°C / 526	50°C / 987	60°C / 1250
Thermal Outputs: (Watts)	30°C / 154	50°C / 289	60°C / 361
Pipe Centres - If Vertical:	520mm		
Pipe Centres - If Horizontal:	N/A		
Max Projection:	230mm		
Tube Diameter:	32mm		
Packaging Volume (L):			
Wall to Centre of Tappings:	N/A		
Floor to Centre of Tappings:	N/A		
Dual Fuel:	N/A		
IP Rating:			