

Sales Code: M900Q-E8

Description: 900 Double Door Quad 8mm

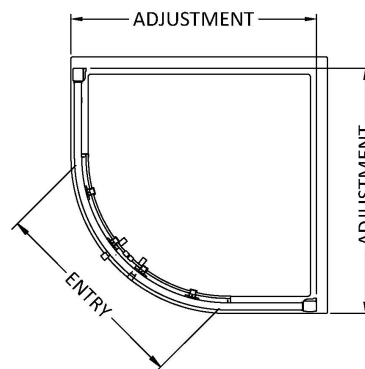
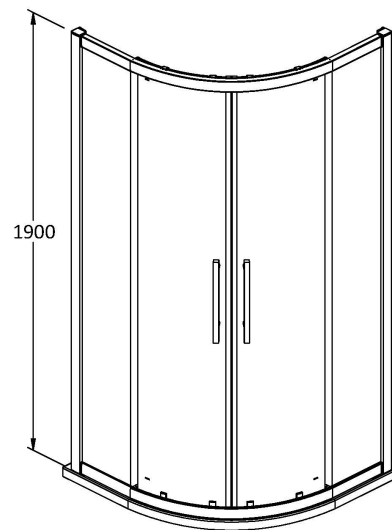

### Product Dimensions

Height (mm):	1900
Width (mm):	880
Depth (mm):	880
Nett Weight (kg):	59.7

### Packaging Dimensions

Height (mm):	1960
Width (mm):	455
Length (mm):	155
Gross Weight (kg):	59.7

### Packaging Data

Box Colour:	Brown Cardboard Box - Printed
Box Qty:	1
Label Size:	100 x 50
Label Colour:	Not Applicable
Label Qty:	0

### Outer Box Dimensions (If Applicable)

Height (mm):	
Width (mm):	
Depth (mm):	
Length (mm):	
Gross Weight (kg):	
Barcode:	5055369080526

### Product Details

Country of Origin:	China
Fitting Instruction:	No
CE & UKCA:	Yes
Profile Material:	Aluminium
Profile Finish:	Polished Chrome
Adjustments (mm):	860mm - 880mm
Entry Width (mm):	520mm
Swing In Dim (mm):	N/A
Swing Out Dim (mm):	N/A
Radius (mm):	538 mm
Glass Thickness (mm):	8
Easy Fit:	Yes
Easy Clean:	Yes
Handle Style:	Square T Shape Handle
Handle Material:	Metal
Enclosure Design:	Framed
Wheel Type:	Dual, Quick Release
Support Bar Included:	Support Bar Not Included
Extras:	Screw Cover Strip