

Sales Code: NPH2262

Description: Tall Unit 1433 X 350 X 255

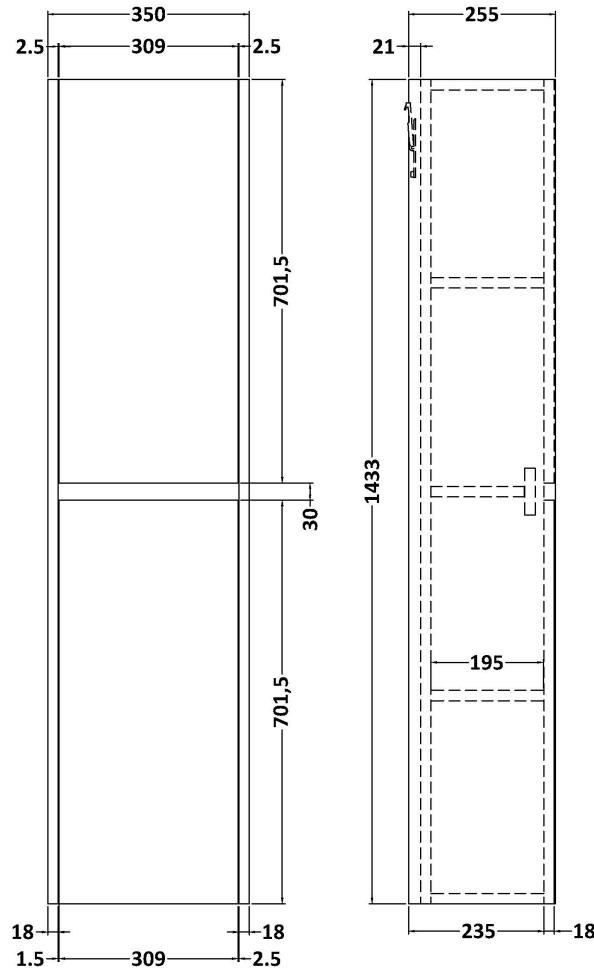
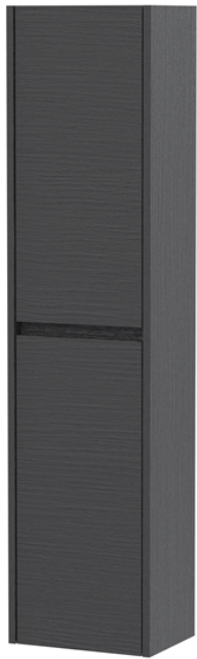

### Product Dimensions

Height (mm):	1433
Width (mm):	350
Depth (mm):	255
Nett Weight (kg):	20.5

### Packaging Dimensions

Height (mm):	1453
Width (mm):	370
Depth (mm):	275
Gross Weight (kg):	21

### Packaging Data

Box Colour:	Brown Cardboard Box
Box Qty:	1
Label Size:	50 x 100
Label Colour:	White Label
Label Qty:	2

### Outer Box Dimensions (If Applicable)

Height (mm):	
Width (mm):	
Depth (mm):	
Gross Weight (kg):	
Barcode:	5056462696621

### Product Details

Country of Origin:	United Kingdom
Fitting Instruction:	No
CE & UKCA:	
FSC Certified Materials:	Yes
Colour:	Graphite Grey Woodgrain
Construction Method:	Cam & Wood Dowel
Construction Type:	Rigid
Cabinet Finish:	MFC Textured Woodgrain
Fascia Finish:	MFC Textured Woodgrain
Cabinet Thickness (mm):	18
Fascia Thickness (mm):	18
Drawer Included:	No
Drawer Type:	Not Applicable
No of Shelves:	3
Hinge Type:	95 Degree Clip-On Soft Close
Hinge Included:	Yes, Supplied
Adjustable Legs:	No, Not Required
Fixings Included:	Yes
Handle Style:	Not Applicable
Waste Shroud:	No
Handle Included:	No, Not Required
Handle Type:	Handleless