

Concept Freedom 60cm Accessible Washbasin

ILLUSTRATED

- E5501** Concept Freedom 60cm accessible washbasin, no taphole
- E0157** Wall fixing set
- S7423** Contour 2 wall mounted single control concealed washbasin mixer with quarter turn ceramic disc operation, 230mm projection spout with alternative aerator or flow straightener outlet, rigid copper tails integral combined filter and regulating valves
- E0079** Trap 1½" Contemporary metal bottle, 75mm seal

OPTIONS

- A6169** Sensorflow Wave thermostatic built-in basin mixer with 230mm spout, mains

ILLUSTRATED PRODUCT DETAILS





Weights

- E5501** 14.00 KG
- E0157** 0.16 KG
- S7423** 1.00 KG
- E0079** 1.45 KG

Materials

- E5501** Vitreous China
- E0157** Metal
- S7423** Chrome Plated Brass
- E0079** Chrome Plated Metal

Finishes

- E5501**  White (01)
- E0157**  Neutral / No Finish (67)
- S7423**  Chrome (AA)
- E0079**  Chrome (AA)

Designer

Robin Levien, RDI

Standards

Washbasin to BS EN 14688 & BS EN 31. Conforms to Doc M and HTM 04

Special Notes

Suitable for use in public areas and Doc M. Satisfies DDA requirements. Washbasin wall mounted using E0157 rag bolts. Please refer to NBN 00-10 Part C sanitary ware assembly for installation heights in healthcare applications.

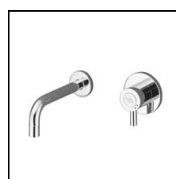
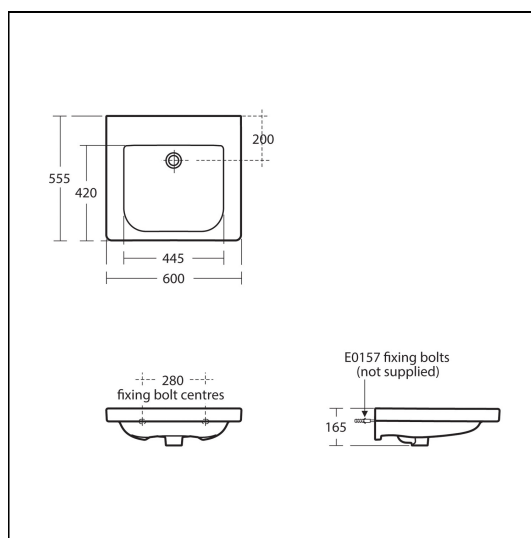

FEATURES

