

9313BL TRIPLE SHOWER VALVE - BLACK



PRODUCT SPECIFICATION

Product Code:	9313BL
Finish:	Matt Black
Product Type:	Concealed Shower Valve
Cartridge Type:	Thermostatic cartridge
Inlet Connections:	3/4 BSP
Outlet Connections:	3/4" BSP
Construction:	Body: Brass, Handles: Zinc, Plates: SS
Gross Weight (kg):	3.04



ADDITIONAL INFORMATION

- Dual Control - flow and temperature are controlled separately giving accurate control of both.
- Thermostatic cartridge maintains showering temperature to +/- 2°C giving a stable outlet temperature.
- Ceramic disc flow control cartridge
- If using a temperature <42°C, automatic shut-off in the event of cold water supply failure to prevent scalding
- Temperature factory set to a 38°C to eliminate the ability to select an unsafe temperature without overriding.
- Two outlet
- Electrophoretic deposition matt black finish
- 3 year guarantee

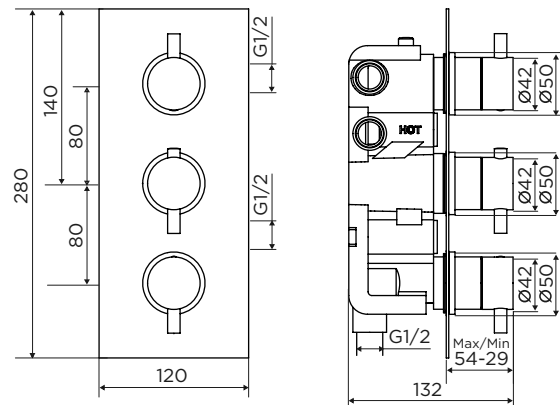

FLOW RATES (litres per minute)

0.5 Bar	1 Bar	3 Bar
6.3	9.1	15.8

WORKING PRESSURES (bar)

Min Pressure	Max Pressure	Best Performance
0.5	5	3

