

Sales Code: NCT300C

Description: W/H Pan

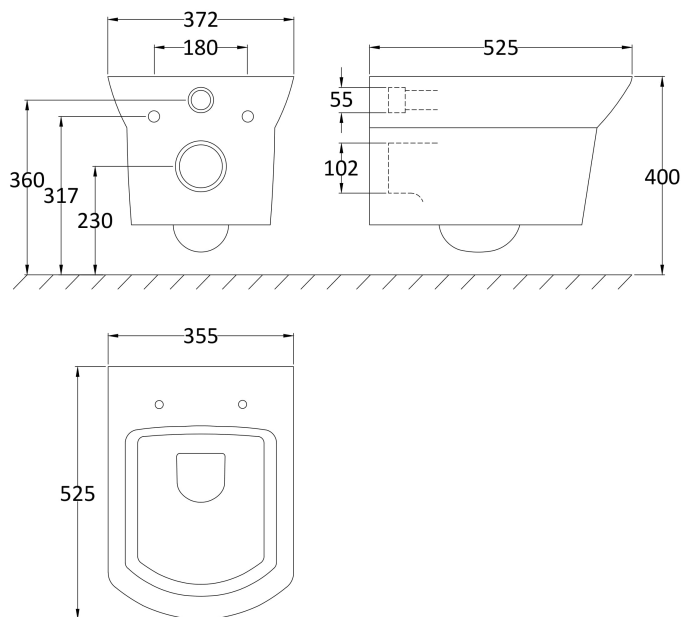

### Product Dimensions

Height (mm):	400
Width (mm):	355
Depth (mm):	525
Nett Weight (kg):	23.7

### Packaging Dimensions

Height (mm):	410
Width (mm):	370
Depth (mm):	550
Gross Weight (kg):	23.7

### Packaging Data

Box Colour:	Brown Cardboard Box
Box Qty:	1
Label Size:	100 x 50
Label Colour:	White Label
Label Qty:	2

### Outer Box Dimensions (If Applicable)

Height (mm):	
Width (mm):	
Depth (mm):	
Gross Weight (kg):	
Barcode:	5055369063338

### Product Details

Country of Origin:	Turkey
Fitting Instruction:	No
Certification: CE & UKCA:	Yes WRAS: N/A WRAS No: N/A
Product Material:	Vitreous China
Fixing Supplied:	No

**Pans/Bidets:** Trap Style: P Trap Includes Seat: No

**Seats:** Seat Type: D-Shape Material: Not Applicable  
Function: Not Applicable Hinge Type: Top Fix  
Hinge Material: Not Applicable

**Cisterns:** Operating Type: Not Applicable Fittings: Not Applicable  
Lever Type: Not Applicable

**Basins:** Tap Hole: Not Applicable Chain Stay Hole: Not Applicable  
Template: Not Applicable Waste Type Req: Not Applicable  
Overflow Inc: Not Applicable Overflow Cover: Not Applicable  
Inner Bowl Depth (mm): N/A