

Sales Code: WIN8TR02

Description: Windon Triple Thermostatic Valve

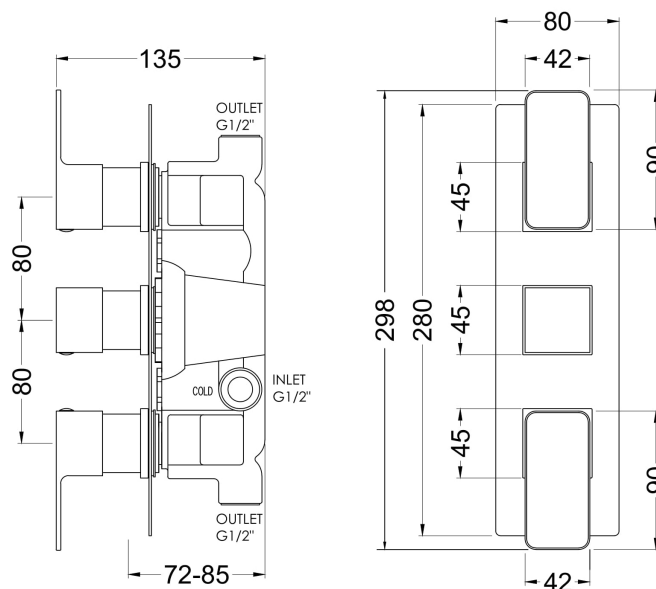
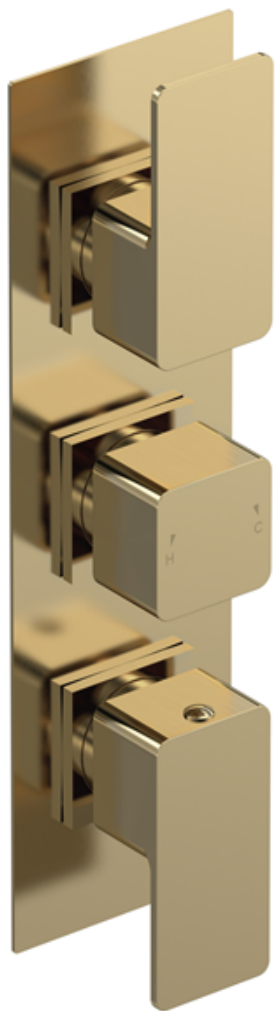

Product Dimensions

Length (mm):	
Width (mm):	80
Height (mm):	280
Depth (mm):	135
Nett Weight (kg):	3.45

Packaging Dimensions

Length (mm):	320
Width (mm):	250
Height (mm):	110
Gross Weight (kg):	3.45

Packaging Data

Box Colour:	White Cardboard Box
Box Qty:	1
Label Size:	100 x 50
Label Colour:	White Label
Label Qty:	1

Outer Box Dimensions (If Applicable)

Length (mm):	
Width (mm):	520
Height (mm):	360
Depth (mm):	340
Gross Weight (kg):	22
Barcode:	5056462623153

Product Details

Country of Origin:	China
Fitting Instruction:	No
Product Material:	Brass/ABS
Mount Type:	Recessed, Wall
Outlet Elbow Supplied:	No
Easy Clean:	Not Applicable
Head Included:	No
Handset Included:	No
Body Jets Included:	Not Applicable
No of Body Jets:	Not Applicable
Operating Pressure (bar):	0.1
Valve/Cartridge Type:	1/4 Turn Ceramic Disc
Flow Rates (L/min):	0.1 bar: 5.5 0.5 bar: 14 1 bar: 20 2 bar: 29 3 bar: 44
TMV2 Approved:	No Approval No: N/A
TMV3 Approved:	No Approval No: N/A
WRAS Approved:	Yes Approval No: 2204707
Head Function:	Not Applicable
Handset Function:	Not Applicable
Body Jet Info:	Not Applicable
Pipe Size:	15 mm & 22 mm
Pipe Centres:	N/A
Colour/Finish:	Brushed Brass
Hose Included:	Not Applicable
No. of Outlets:	2