

Sales Code: E323

Barcode: 5056211817529

Brand: nuie

Description: White Waste Trap For Furniture Basins

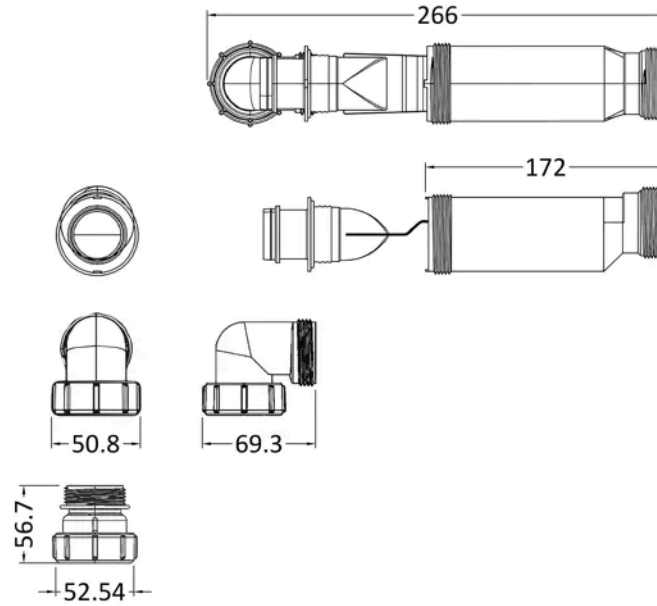

Product Dimensions

Product	57 x 53 x 266mm (H x W x D)
Packaged	250 x 32 x 32mm (H x W x D)
Nett Weight	0.25 kg
Packaged Weight	0.26 kg

Packaging Details

Label Size (mm)	50 x 100
Label Colour	White
Label Qty	2.0000

Product Details

Country of Origin	United Kingdom
Product Material	Polypropylene
Colour/Finish	White
Style	Contemporary