

Sales Code: NLT61063

Barcode: 5056462656427

Brand: nuie

Description: 1700 x 800mm Slate Rectangular Slimline Shower Tray

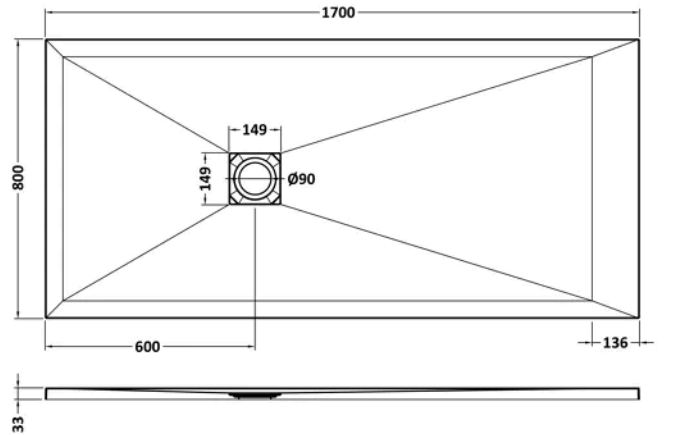

Product Dimensions

| | |
|-----------------|-------------------------------|
| Product | 33 x 800 x 1700mm (H x W x L) |
| Packaged | 73 x 840 x 1740mm (H x W x D) |
| Nett Weight | 66.6 kg |
| Packaged Weight | 66.9 kg |

Product Details

| | |
|---------------------|---------------------------------|
| Country of Origin | United Kingdom |
| Product Material | Acrylic Capped Abs Caco3 And Pu |
| Colour/Finish | White Slate |
| Style | Contemporary |
| Ce Certified | Yes |
| Leg Set Included | No |
| Legs Included | No |
| Slip Resistant | No |
| Waste Included | No |
| Waste Shape | Square |
| Waste Size Required | 90mm |