

**Sales Code:** NLT61106

**Barcode:** 5056462656151

**Brand:** nuie

**Description:** 900 x 900mm Slate Quadrant Slimline Shower Tray

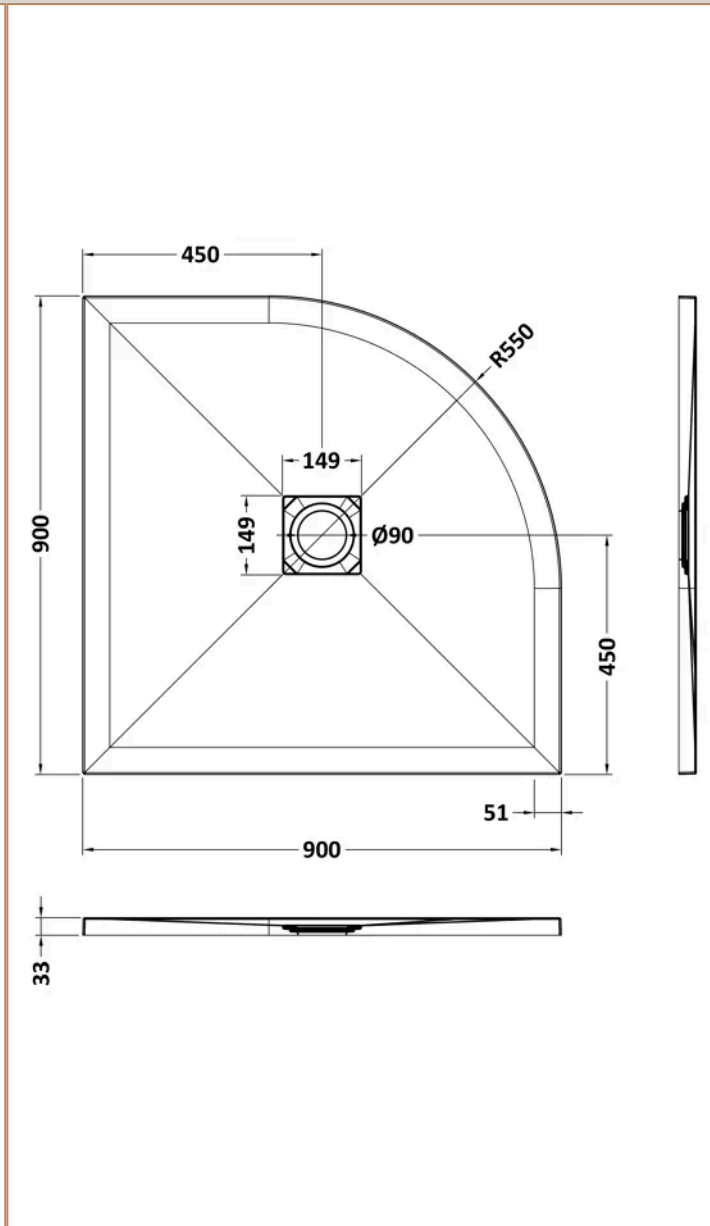

### Product Dimensions

Product	33 x 900 x 900mm (H x W x L)
Packaged	73 x 940 x 940mm (H x W x D)
Nett Weight	33.5 kg
Packaged Weight	33.8 kg

### Product Details

Country of Origin	United Kingdom
Product Material	Acrylic Capped Abs Caco3 And Pu
Colour/Finish	White Slate
Style	Contemporary
Ce Certified	Yes
Leg Set Included	No
Legs Included	No
Waste Included	No
Waste Shape	Square
Waste Size Required	90mm