

# PRODUCT DATA SHEET

## Manhattan Matt Black Kitchen Tap

Product Code:KT43



**SCUDO**  
BEAUTIFUL BATHROOMS

0330 124 7290

sales@scudo.co.uk - www.scudo.co.uk

Scudo is the trading name of Harrison Bathrooms Ltd. Whilst we endeavour to ensure that the product information is accurate we accept no liability for any information given. All images are for illustration purposes only. Product images and specification are subject to change. Measurement are in millimetres and are nominal.

### Product Measurements

Product Weight:	1.4kg
Product Width:	52.5mm
Product Height:	367mm
Product Depth:	N/A
Product Length:	200mm

### Product Transportation

Barcode:	5060766122212
Country of Origin:	China
Comodity Code:	8481801190

### Primary Packed Measurements

Packaged Weight:	1.7kg
Packaged Length:	238mm
Packaged Width:	435mm
Packaged Height:	55mm

### Packaging Weight

Card:	0.25kg
Paper:	0kg
Wood:	0kg
Plastic:	0.015kg

### General Information

Construction Material:	Stainless Steel Alloy 304
Installation Type:	Deck Mounted
Colour / Finish:	Matt Black

### Tap/Shower Attributes

Minimum Pressure:	0.5 bar
Maximum Pressure:	5 bar
Flexible Tails Included:	Yes
Tap Hole Required:	1
Handle Type:	Lever
Swivel Spout:	Yes
Inlet Connection:	1/2" M10
Outlet Connection:	N/A
Tap Hole Diameter:	35mm
Tap Type Description:	Mono Mixer
Includes Waste:	No
Valve / Cartridge Type:	Single Lever Cartridge 35mm
Cartridge Spare Code:	spares@harrisonbathrooms.com

### Flow Rates

0.2bar (l/min)	3.8
0.5bar (l/min)	5.4
1bar (l/min)	7.2
2bar (l/min)	10.8
3bar (l/min)	12.4

### Compliance DOP

HBDOC007 / HBDOC008

For Part G Building regulations, compliance see flow regulator section of spec binder.

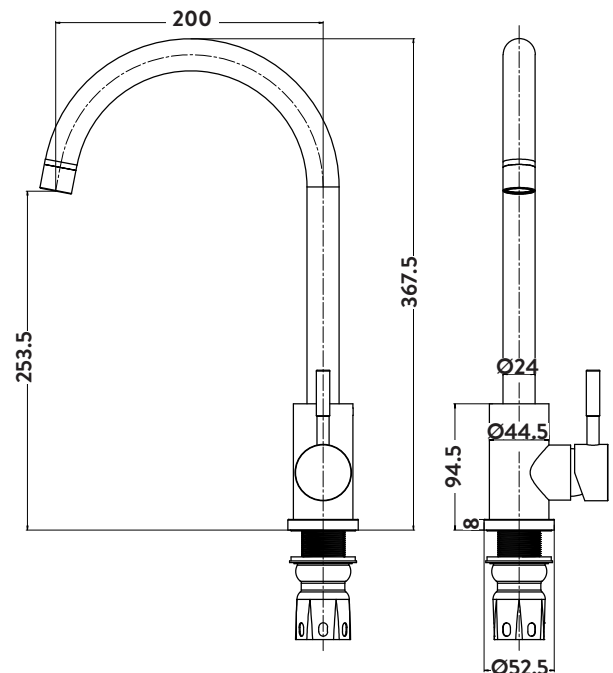

**Dimensions**  
(measurements in mm)



### LIFETIME GUARANTEE

We are confident in our products and we want our customer to be, we proudly give a lifetime guarantee on our taps and showers, further details can be found on our website