

OPTIONS 600 - WALL MOUNTED PAN



ILLUSTRATION:

CODE: WALL HUNG PAN -
SOFT CLOSE SEAT -

POT077OP
POT082OP
POT084OP

COLOUR: WHITE

WEIGHT:	WC PAN	SEAT
NET:	19 KG	KG
GROSS:	20 KG	KG

STANDARDS: BS EN 997 WCs
BS 3402



NOTES:
VITREOUS CHINA

SOFT CLOSE SEAT WITH QUICK RELEASE TOP FIX HINGE

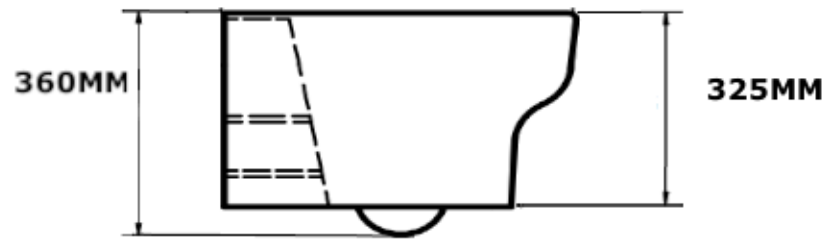
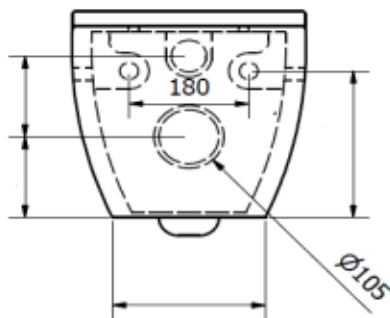

485MM

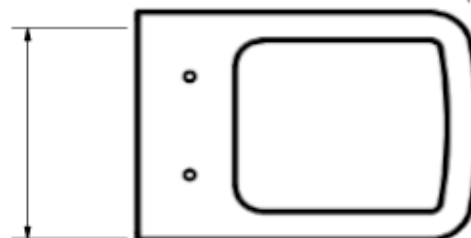

***Images for
Illustration
only***

BOX SIZES :- WC PAN = 390mm x 540mm x 400mm