

SAGITTARIUS

TAPS & SHOWERING

**MORELLA SLIM 300 X300 MM
SQUARE HEAD AND ARM
SH/801/C**

Finishes	Chrome
Product Type	Contemporary
Standards	-
Certification	-
Weight(net)	-
Size	0.45kg/piece
Fitting	300 x 300mm
Packaging	G1/2"
Guarantee	63 x 33 x 37.5cm / carton (10 boxes / carton)
Additional Information	1 year against manufacturing faults (excluding serviceable parts). 1. Swivel connector : Brass 2. Rub-clean rubber nozzle 3. Aerator/Induction

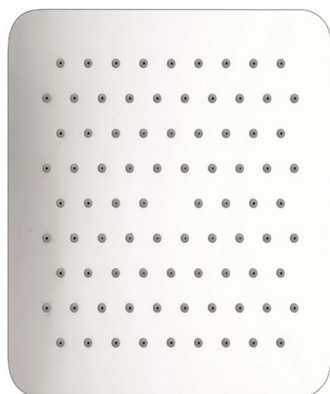
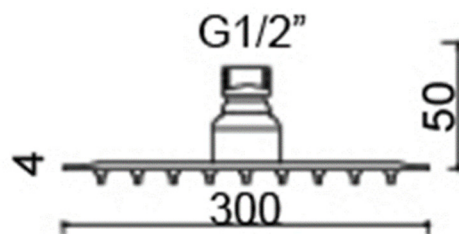

The information contained on this page was correct at the date of issue. Fitting dimensions are provided as a guide only. Some variation may occur due to manufacturing tolerances. We pursue a policy of continuing improvement in design and performance of our products and so reserve the right to change specifications without prior notice

FOR FURTHER ADVICE PLEASE CONTACT :-

SAGITTARIUS LTD UNIT 1 LOWER VICTORIA STREET—CHADDERTON—OLDHAM—OL9 9TU TEL:0616 6202029

EMAIL:TECHNICAL@SAGITTARIUSTAPS.CO.UK

Construction
Finishes
Product Type
Plumbing Systems
Certification
Fitting
Packaging
Guarantee

Brass Body (CuZn38Pb18)
 Chrome plated to BS EN 248
 Contemporary
 Suitable for all plumbing systems
 -
 G1/2" BSP
 73 x 48 x 37cm / carton (50 boxes / carton)
 5 years against manufacturing faults (excluding serviceable parts).

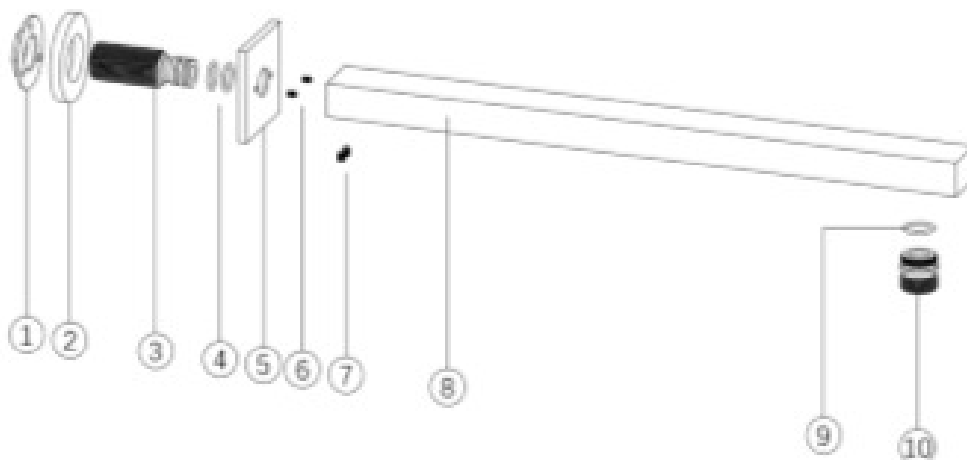
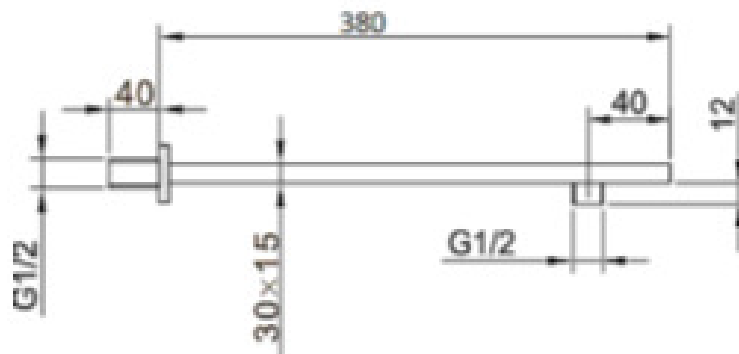

10	SHOWER CONNECTOR	1
9	O-RING	1
8	BODY	1
7	SCREW	2
6	SCREW	2
5	BASE PLATE	1
4	O-RING	2
3	CONNECTOR	1
2	WASHER	1
1	BACK NUT	1
No.	DESCRIPTION	QTY

The information contained on this page was correct at the date of issue. Fitting dimensions are provided as a guide only. Some variation may occur due to manufacturing tolerance.
 We pursue a policy of continuing improvement in design and performance of our products and so reserve the right to change specifications without prior notice.

FOR FURTHER ADVICE PLEASE CONTACT :-

SAGITTARIUS LTD UNIT 1 LOWER VICTORIA STREET—CHADDERTON—OLDHAM—OL9 9TU TEL:0616 6202029

EMAIL:TECHNICAL@SAGITTARIUSTAPS.CO.UK