

Salamander Pumps 

# Pump installation and warranty guide for CombiBoost and HomeBoost

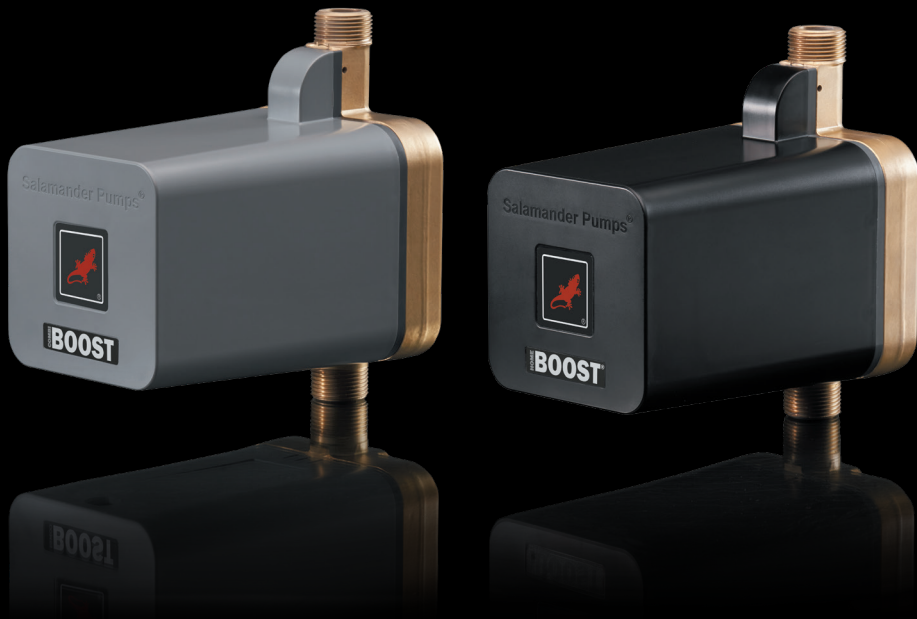

This document should be given to the end user and retained for future reference. Should you need to contact Salamander Pumps you will need the below information.



**MADE IN BRITAIN** 

**WRAS**  
APPROVED PRODUCT



HomeBoost only

ISSUE 3  
JAN 2023

# Pump installation and warranty guide for HomeBoost and CombiBoost

## Important – read this first!

HomeBoost™ and CombiBoost have two separate and distinct applications. The first is for use on the incoming domestic cold water mains supply, and the second is directly on the combi-boiler cold water inlet.

HomeBoost™ is designed to boost your existing incoming mains water supply up to 12 litres per min (lpm). The intelligent control ensures that it reacts and responds to give a stable outflow, and is unrestrictive if your natural water flow reaches 12lpm or more naturally.

CombiBoost is designed to boost your existing incoming mains water supply up to 10 litres per min (lpm).

Correct installation is essential for safe operation and a trouble free system. It is therefore important to read these instructions thoroughly and ensure that you comply with them. Incorrect fitting will invalidate the warranty.

If your installation is complicated or you have any questions, please consult the PumpWise Technical Helpline immediately (0191 516 2002).

We encourage installers to consult the Salamander helpline before installation, where our technical advisers can give you professional advice regarding installation. When the job is finished, please complete the warranty registration on our website [www.salamanderpumps.co.uk](http://www.salamanderpumps.co.uk) or by calling 0191 516 2002.

Please leave this installation guide with the customer for reference to maintenance and safety information.

Thank you for choosing

Salamander Pumps

## Contents

Pre-installation checklist	2
Application notes	3/4
Typical installations	5
Commissioning	6
General specifications	7
Lighting codes & Trouble shooting	9
Fittings Kit	10
PumpWise and warranty	11
To the installer	12
Terms and conditions	12

# Pre-installation checklist

HomeBoost™ and CombiBoost are suitable for two separate types of water boosting applications:

1. Boosting the incoming mains water supply to a whole house
2. Boosting the inlet mains water supply solely to a combination (combi) boiler.

Points applicable to either installation type:

## Do's

- HomeBoost™/CombiBoost must be fitted to rigid fixed pipework preferably with vertical inlet and outlet
- Pipework above and below the pump must be securely fixed to the wall
- Only one HomeBoost™/CombiBoost may be fitted per household supply
- Ensure that installation complies with IET Wiring Regulations
- Allow 100mm on all sides for ventilation
- Ensure pump is protected from frost
- Complete all hot work fitting prior to HomeBoost™/CombiBoost installation
- We recommend that the pump is activated for at least five minutes every four weeks
- If the supply is known to be lime/calcium (hard) water, fit extra filtration before the pump. Always consult filter manufacturer's literature for correct installation.

## Don'ts

- Never fit to hot water piping
- Never fit the pump to communal risers
- Never pump directly from or to another pump
- Never fit to flexible pipework (e.g. tap connectors)
- HomeBoost™/CombiBoost cannot be used on outside coldwater storage tanks, bore holes or wells
- Never use jointing compounds, Boss White, hemp or steel wool
- Solder fluxes must not come into contact with the pump
- Never fit HomeBoost™/CombiBoost upside down

## Points applicable to whole house installation:

### Do's

- Install vertically or horizontally, mounted on cold water mains inlet to the house
- Locate the pump next to the mains stop tap
- Pump should be fitted before ANY other water outlets taken after the mains stop tap. If any outlets are between the stop tap and your HomeBoost™/CombiBoost, they must be fitted with a non-return valve

## Points applicable to combi-boiler installation:

### Do's

- Install vertically or horizontally, mounted on cold water mains inlet to the combi boiler
- Locate the pump next to the combi-boiler OR on its cold water mains inlet
- Pump must exclusively feed the combi-boiler

# Application notes

Please follow these pre-installation instructions carefully. Failure to install your HomeBoost™/CombiBoost in accordance with these instructions will invalidate your warranty.

## 1. Location of HomeBoost™/CombiBoost

The best possible location of the HomeBoost™/CombiBoost is on the cold water mains supply to the house, after the mains stop tap or on the combi boiler inlet, depending on the installation.

### 1.1 Cooling and ventilation

The HomeBoost™/CombiBoost should be placed in a position where there is adequate air flow to cool the motor and separated from any other appliances that generate heat.

### 1.2 Frost protection

HomeBoost™/CombiBoost must be protected from frost damage.

## 2. Cold supply to the HomeBoost™/CombiBoost

HomeBoost™/CombiBoost must be fitted directly to the cold water mains house supply, or the mains water inlet to the combi boiler as indicated in the pre-installation checklist. Never fit to communal risers (e.g. block of flats).

## 3. General plumbing

Please note that the HomeBoost™/CombiBoost is designed to boost incoming water flow under low pressure conditions.

Installation must comply with the relevant requirements or local byelaws.

It is recommended that HomeBoost™/CombiBoost is installed vertically, and every effort should be made to accommodate this. However, HomeBoost™/CombiBoost will function correctly if installed horizontally. It must be adequately vented, protected from frost, and with access provided for servicing.

Jointing compounds, Boss White, hemp and steel wool **MUST NOT BE USED. SOLDER FLUXES MUST NOT COME INTO CONTACT WITH THE PUMP. THIS WILL INVALIDATE YOUR WARRANTY.**

Supplied inlet strainer must be fitted to the inlet supply of the HomeBoost™/CombiBoost. All outlets which are located between the mains stop tap and the HomeBoost™/CombiBoost must be protected by non-return valves. This is to prevent backflow of water and air from these outlets to the HomeBoost™/CombiBoost, which will cause damage to the pump.

Suitable for maximum inlet pressure of 1MPa (10 bar).

In line with good plumbing practice and water regulations, ensure that a non-return valve has been fitted directly after the mains stop tap to the house. Earth continuity must be maintained.

# Application notes – continued

## 4. Isolation valves

Good plumbing practice is to fit full bore isolating valves into the inlet and outlet pipe work of the pump to facilitate service and removal of the pump. To install immediately after the stop tap, the isolation valve should be fitted to the pump outlet. To install to a combi boiler only, the isolating valve should be fitted to the pump inlet.

## 5. Holding the HomeBoost™/CombiBoost during installation

To hold HomeBoost™/CombiBoost during installation, spanner flats (24mm) have been provided on the brass neck outlet. See Figure 1. Any tool used to hold HomeBoost™/CombiBoost while the pipework is connected must be located on the brass portion of the neck to avoid damage to the polymer pump body.

## 6. Electrical requirements

HomeBoost™/CombiBoost must be connected to the electrical supply using the mains cable with the attached plug. This plug must be connected to an accessible socket that has been installed in compliance with IET Wiring Regulations.

The plug must be accessible at all times.

If the supply cord is damaged, it must be replaced by the manufacturer, its service agent, or similarly qualified person in order to avoid a hazard.

All pipe work must be cross-banded in accordance with the IET Regulations.

HomeBoost/CombiBoost™ is supplied with a 3A fuse fitted. Higher rated fuses MUST NOT be used.

If installed by a Part P qualified installer, the pump may be fitted via a 3A fused mains spur without invalidating the warranty.

Figure 1: Spanner flats to hold the HomeBoost/CombiBoost during installation

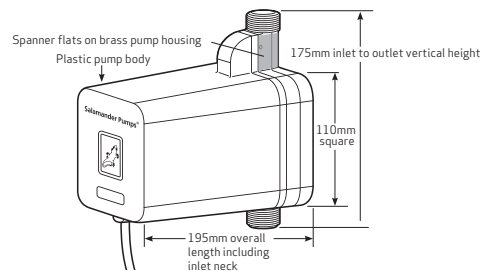

Figure 2: Inlet and outlet



# Typical installations

Figure 3: Ideal location

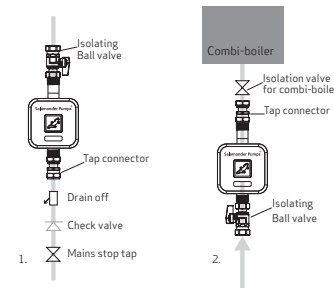

Figure 4: Modified pipe work for clearance

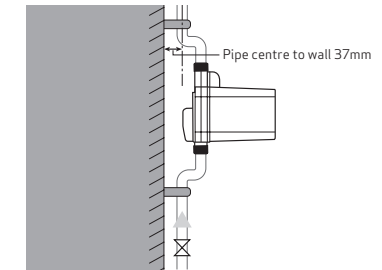

Figure 5: Typical installation locations

NOTE: Refer to pre-installation checklist for suitability

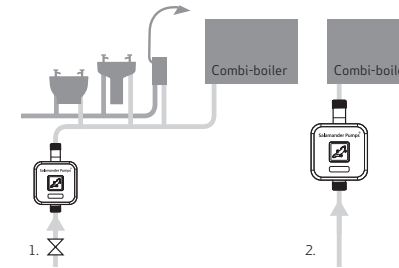

Figure 6: Earth continuity (4mm² earth connection cable)

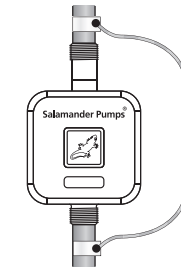

Figure 7: Incorrect installation location

NOTE: Refer to pre-installation checklist for suitability

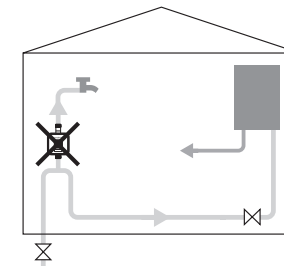
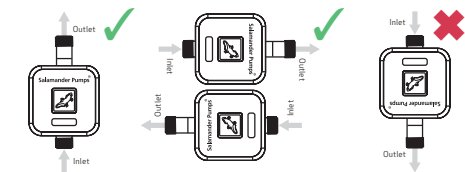

Figure 8: Installation orientation

NOTE: Pump can be installed horizontally or vertically but not upside down.



# Commissioning

## Before you finish

- Check the pump inlet filter is fitted
- With HomeBoost™/CombiBoost installed, flush the inlet pipe work and fully fill the pump with water by opening all the water outlets BEFORE electrically switching the pump on.

### It is critical to discharge water through the pump through;

1. all the cold outlets on a whole house application.
- or
2. all the hot outlets for a combi boiler boost application. Using natural flow before switching the pump on electrically. This will ensure that the air has been discharged from the connecting pipe work and pump chamber.

The best method is:

- 1 Connect pump pipe work
- 2 Check that all isolating valves are open
- 3 Turn mains water on at the stop tap
- 4 Ensure all air is purged from the system
- 5 Check for natural flow on the cold outlets (or hot outlets for a combi boost installation)
- 6 Inspect connecting pipe work for leaks
- 7 Plug in electrical supply to pump
- 8 Turn mains electrical supply on
- 9 Green pump lights in the logo label should be lit and steady. This indicates that the power is on and that the pump is ready for use (HomeBoost™ only)
- 10 Turn a pumped outlet on
- 11 HomeBoost™/CombiBoost should activate. The green lights should rotate, indicating that the pump is in operation (HomeBoost™ only).

If the HomeBoost™/CombiBoost does not activate, please refer to the trouble shooting section of these application notes.

# General specifications

## Applications

HomeBoost™/CombiBoost pumps are designed to boost low mains water flow into a domestic house to improve low water flow from the mains supply at peak demand times. These pumps can be used in two distinct applications:

1. Boosting the incoming mains water supply to a whole house
2. Boosting the inlet mains water supply solely to a combination (combi) boiler.

HomeBoost™ will increase the low incoming water flow up to 12 lpm and CombiBoost will increase to 10 lpm which comply with the Water Supply (Water Fittings) Regulations 1999. HomeBoost™ will adapt to maintain 12 l/min, and will move into idle if sufficient flow is received from the water main.

## Power supply

230 volts, 50Hz, 1.8A, continuously rated.

## Pump noise

The HomeBoost™ pump has been awarded the quiet mark, demonstrating that it is one of the quietest pumps available in its category. However, no pump is completely silent and this type of pump is characterised by a high pitched hum or whine.

## Mechanical seals

Scale deposits in water supplies can cause the mechanical seal to stick if left for long periods without use. We recommend that the pump be run for at least five minutes every four weeks to 'exercise' all the working parts.

## Connections

¾" BSP male.

## Initiation

Fully automatic, water flow operated, requiring 3 litres per minute flow rate to initiate.

## Temperature

Maximum fluid temperature is UK cold water mains temperature (max 20°C).

## Standards and approvals

- WRAS approved product
- Complies with the Water Supply (Water Fittings) Regulations 1999
- Splash proof rating IPX4
- Complies with European Community Directives (CE)
- Tested for sound power level in accordance with methods set out in BS EN ISO 3744:2010 and

BS EN ISO 20361:2009, and results calculated to BS EN ISO 11203: 2009

- EN 55014-1:2006 Electromechanical compatibility (EMC) – Requirements household appliances, electrical goods and similar apparatus (Part 1)
- EN 60335-1:2002 and EN 60335-2-41:2003 Household and similar electrical appliances – safety (Part 1 General requirements and Part 2-41 Particular requirements for pumps).

The company operates a policy of continuous development and reserves the right to change any of the specifications of its products without prior notice. All information data and illustrations given in this leaflet may be subject to variation.

## Safety in operation

These appliances are not intended for use by persons (including children) with reduced physical, sensory or mental capabilities, or lack of experience and knowledge, unless they have been given supervision or instruction concerning use of the appliance by a person responsible for their safety. Children should be supervised to ensure that they do not play with the appliance.

## WEE Directive

Your appliance contains valuable materials which could be recovered or recycled. At the end of the product's useful life please dispose of it at an appropriate civil waste collection point.



### WEEE Directive 2012/19/EU

At the end of the product life dispose of packaging and product in a corresponding recycling centre.

Do not dispose of the unit with the usual domestic refuse. Do not burn the product.

## Lighting codes (HomeBoost™ only)

Lighting pattern	Denotes
On steady and dim	Power on
Slow clockwise	Pump in normal running mode
Fast clockwise	Pump in high speed running mode
Single sideways flash	Overheat (motor speed will be limited until temperature drops, or will cut off completely for safety in extreme cases)
Flashing diagonally	Sufficient mains water flow through pump without pump running

## Trouble shooting

Fault	Probable cause	Recommended solution
Pump will not start	Electrical	Check power supply (appliance plugged in and electrical power on) Check fuse Check circuit breaker
	Inlet/outlet connections	Check that the connections are plumbed in the correct way round and all valves are open
	Insufficient mains flow	Check that the installation complies with the Salamander instructions Check inlet filters are not blocked Check stopcock and all isolating valves are fully open Check natural flow rate minimum of 3litres/min
	Over temperature (single sideways light flashing) (HomeBoost only)	Leave pump turned off for ten minutes to cool down Then re-attempt start up routine
	Natural flow >10lpm (CombiBoost) Natural flow >12lpm (HomeBoost)	Diagonal flash, normal pump function (HomeBoost only)
Pump starts and lights flash diagonally (HomeBoost™ only)	Sufficient mains water flow	HomeBoost™ not required to run at this time. Pump will only run during periods of low water flow
Reduced/ intermittent flow	Insufficient mains flow	See above
	Blocked inlet filter	Ensure that inlet filter is free from debris
	Air in system	Run system on full cold for a whole house install, or full hot in a combi boiler install, with pump switched off (i.e. mains water supply only) for several minutes
Pump starts with all outlets closed	Leak in system	Check for leaks
	Outlet open	Ensure all outlets are fully closed or capped – i.e. no dead legs in pipework
Pump is noisy	Air in system	See above
	Pump vibrating against other pipework	Move pump away from contact with other pipe work
	Pump running hard	Check filters and unblock if necessary
Pump is leaking	Pump has suffered chemical damage	Ensure that pump has not come into contact with chemical substance i.e. solder flux
	Pump exposed to extreme temperature	Ensure adequate frost protection
	Pump appears to have leaked but not sure	Check leak is not from fitting in pipe work above pump Check condensation build up – drain holes in the base of the pump casing should allow excessive water to drain off

# Fittings kit (not included)

Purchase separate - ACCHBFIT01 from <https://shop.salamadnerpumps.co.uk/>

## Contents

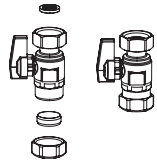

1 x Ball valve  
3/4" Tap connector x  
22mm compression

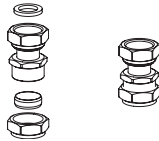

1 x tap connector  
3/4" Tap connector x  
22mm compression

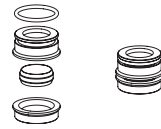

2 x reducer  
22mm x 15mm  
compression reducer

## Fitting instructions

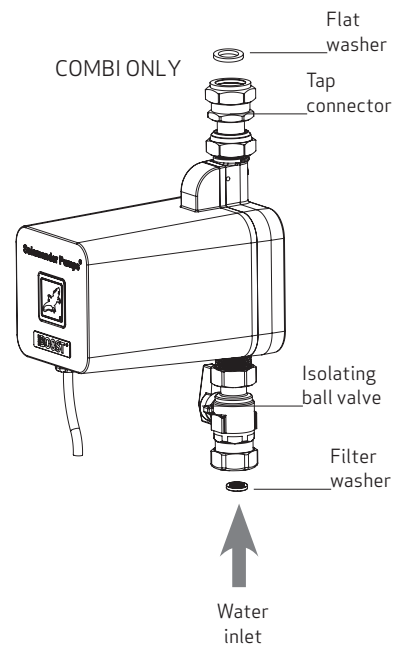
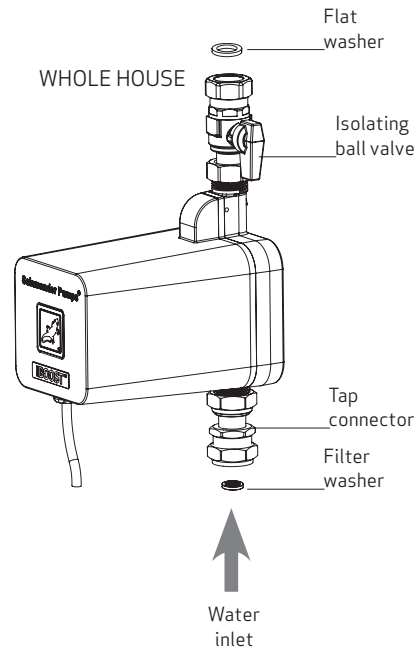

# PumpWise and warranty

0191 516 2002

Monday to Thursday 8.00am to 5.30pm, Friday 8.00am to 5.00pm.

PumpWise is the cornerstone of Salamander's support service to our customers and the means by which our customers are guaranteed:

- Selection of the right pump for the job

With more than 30 pumps in our range, the PumpWise team can help you to choose the pump that's most suitable to your specific installation.

- The avoidance of installation pitfalls

Due to the technical nature of our products, it is essential that they are fitted according to our installation guidelines. The PumpWise team are available to talk through any installation questions and provide technical support and guidance.

- Warranty

- HomeBoost™ has a three year warranty. CombiBoost has a one year warranty.

## Our PumpWise commitment

Our PumpWise helpline is here to help you and we aim to provide a support service second to none. Installers and consumers can be sure of a speedy response to requests for technical help, guidance, and advice.

## Your warranty

HomeBoost™ comes with a three year warranty and CombiBoost comes with a one year warranty.

This warranty will operate from the date of purchase and is subject to the installation guidelines being followed correctly (please refer to our Pre-Installation checklist and our Commissioning checklist).

Please complete the warranty registration on our website [www.salamanderpumps.co.uk](http://www.salamanderpumps.co.uk) or by calling 0191 516 2002.

For further details please contact the PumpWise team:

Telephone: 0191 516 2002

Fax: 0191 548 4445

Email: [tech@salamanderpumps.co.uk](mailto:tech@salamanderpumps.co.uk)

PLEASE NOTE: Incorrect installation will invalidate the pump warranty. Please fully read the following terms and conditions.



## To the installer

Please follow the guidelines for the installation provided in this brochure and call the PumpWise helpline for installation advice. Once installation has been completed and the system has been tested to your satisfaction, please assist the customer by giving them the information needed to complete the online warranty registration.

Please note that Salamander are able to provide an onsite service visit which may be chargeable.

## Terms, conditions and warranty

### 1. The Scope of the Warranty

SALAMANDER PUMPED SHOWER SYSTEMS LTD (“the company”) Warrants subject to the terms and conditions below for the Warranty period(s) specified in paragraph 3 that the Company shall:

Repair or replace free of charge the product(s) specified on the Warranty registration or any component part thereof (together referred to as “the equipment”) which shall in the opinion of the Company have proved defective by reason only of the Company’s materials or workmanship providing always that the Company shall be under no obligation whatsoever under this Warranty to repair or replace equipment which shall have been misused modified altered or transformed in any way without the consent in writing of the Company or if any component or accessory shall have been replaced by a type not specified by the Company or if the equipment is incorrectly installed or operated or used other than as described in the instruction manual or if any servicing or repair of the equipment shall have been carried out otherwise than by an authorised Company dealer appointed by the Company (“dealer”).

The Company’s liability under this Warranty is limited to the said repairs or replacement and shall under no circumstances extend to any financial loss or damage including consequential losses alleged to have been suffered by the claimant.

Subject as provided in this warranty and except where the equipment is sold to a person dealing as a consumer all warranties, conditions or other terms implied by law are excluded to the fullest extent permitted by law.

Nothing in this warranty shall exclude liability for death or personal injury caused by the Company’s negligence.

### 2. Terms and conditions

This Warranty shall only be enforceable by you if the following terms and conditions have been complied with:

- a That the pump has been installed in accordance with the installation instructions, guidance and advice contained within the installation and warranty guide and/or provided by the Salamander help desk.

- b You are the original purchaser of the equipment from a dealer and not an assignee or subsequent purchaser of the equipment.
- c You must evidence the date of purchase by retaining the original invoice from the dealer. Without such evidence the Company reserves the right to reject any such claims under the terms of this Warranty.
- d Within 15 days of delivery of the equipment to you the Warranty is registered with the Company.
- e Within thirty days of discovery of a defect giving rise to liability under paragraph 1 above you give notice thereof in writing to the Company.

### 3. The Warranty periods

The Warranty periods referred to in paragraph 1 above are as follows:

- a HomeBoost product manufactured by the Company three years from date of purchase and CombiBoost product manufactured by the Company one year from date of purchase provided the warranty is registered with the Company within 15 days of purchase.
- b Products supplied by the Company, but not of the Company’s manufacture – one year from date of purchase.
- c The warranty period in respect of any product repaired or replaced under the warranty shall be part of the above period(s) which remain unexpired.
- d In the event of a claim for repairs or replacement being made under the terms of this Warranty in the circumstances where in the opinion of the Company the defect has not been caused by the Company’s materials or workmanship then the Company reserves the right to charge the claimant at its current hourly rates and list prices in respect of any service engineer’s time and any replacement of parts.
- e This Warranty is given in addition to and does not affect your statutory rights as a consumer.
- f This Warranty is valid and enforceable for equipment purchased and used exclusively in the UK and The Republic of Ireland only.
- g Where the Company makes a replacement the equipment replaced shall be returned to the Company forthwith and shall become the property of the Company.
- h No authority has been given to any person, firm or company to vary the terms of this Warranty.



Get in touch,  
we're here to help  
call us on  
0191 516 2002

Unit 2c Colima Avenue  
Enterprise Park West  
Sunderland, SR5 3XE



## Register your warranty

Apply online at:  
[www.salamanderpumps.co.uk](http://www.salamanderpumps.co.uk)

Apply by phone:  
0191 516 2002



HomeBoost only

**MADE IN  
BRITAIN** 



**Pump**  **wise**